

① "Z" MEAS. TOOL ASSEMBLY

1 REQ'D
NEXT ASSY: NONE

- NOTES:
1. MEASURED ON 1 14 02
 2. TOP OF BRIDGE, D3603: 9.5 FROM DATUM A
 3. ON 8 2 00, DH MEASURED 1.154 FOR THIS DIMENSION.
 4. PARTS DO NOT ASSEMBLE CORRECTLY IN THE REGION OF THE GLUED-ON PADS. THIS NEEDS TO BE DOCUMENTED.

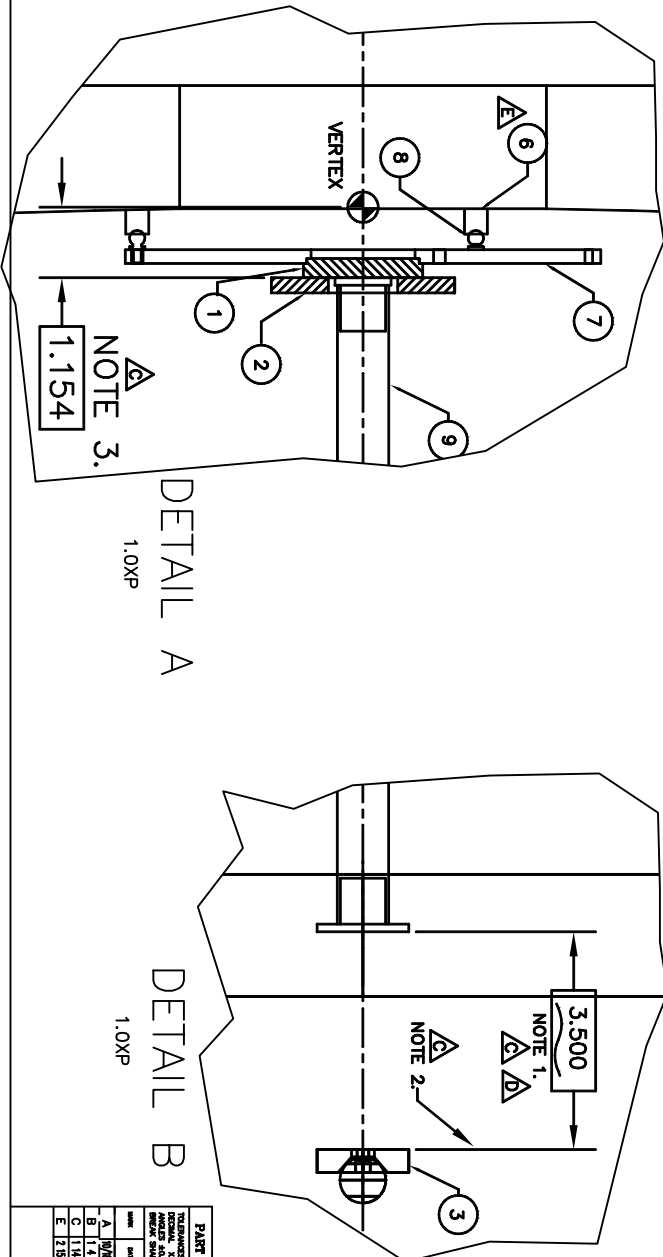

PART NO.	TIME	QTY	DESCRIPTION	MATERIAL	SCALE
D2360-1	9	1	ROD9B		ASSY
D2350-3	8	3	TOOLING BALL	SST	
D2350-2	7	1	PLATE	INVAR	
D2390-1	6	3	PADS	INVAR	
D2397-1	3	1	DRIVE DISK FIXTURE	STL	
D2386-2	2	2	COLLAR	STL	
D2386-1	1	1	SPACER	STL	

PART NO.	TIME	QTY	DESCRIPTION	MATERIAL
			UNIVERSITY OF CALIFORNIA LICK OBSERVATORY	
			KECK/DEMOS	
			COLLIMATOR TOOLING ASSEMBLY	
				D2355.E

DATE	BY	CHKD	APP'D	REVISION
14 MAR 1983	1.0XP			1
14 MAR 1983				2
14 MAR 1983				3
14 MAR 1983				4

TOLERANCE UNLESS OTHERWISE NOTED:	FINISH	OTHER	REMARKS
A. 0.0010 CAD		UPDATE PER REVISION NOTES	
B. 0.0015 CAD		AT TIME OF MEASUREMENT	
C. 0.0020 CAD		MEASURE PADS ON MIRROR	
D. 0.0025 CAD			
E. 0.0030 CAD			

DATE	BY	CHKD	APP'D	REVISION
14 MAR 1983	1.0XP			1
14 MAR 1983				2
14 MAR 1983				3
14 MAR 1983				4