

NOTE: ON EACH AMP-1140, INCOM & LSCOM ARE JUMPERED TO +5V.

UNIVERSITY OF CALIFORNIA
LICK OBSERVATORY

TV FOCUS STAGE WIRING
DEIMOS SPECTROGRAPH

REVISION	
08-09-99	CHANGED PRIMARY LIMITS FROM NORMALLY CLOSED TO NORMALLY OPEN
03-13-00	CORRECTED TBA AND TBB PIN NUMBERS
06-21-00	ADDED CONNECTOR TO FIDUCIAL AND CORRECTED PIN NUMBER ON TB1
08-07-00	CORRECTED PIN NUMBERS ON TB1 IN INTERCONNECT BOX
01-02-01	CORRECTED SECONDARY LIMIT WIRING
09-09-01	ADDED SECOND SHEET
11-20-01	ADDED WIRE COLOR TO MOTOR WIRING

DES'N BY: B. Alcott	ORIGIN DATE: 05-05-95
DRAWN BY:	MODIFY DATE: 11-20-01
PATH: DEIMOS\TVFOCUS	REV. A

DWG. NO.	NUM. 1 OF 2
EL-3051	

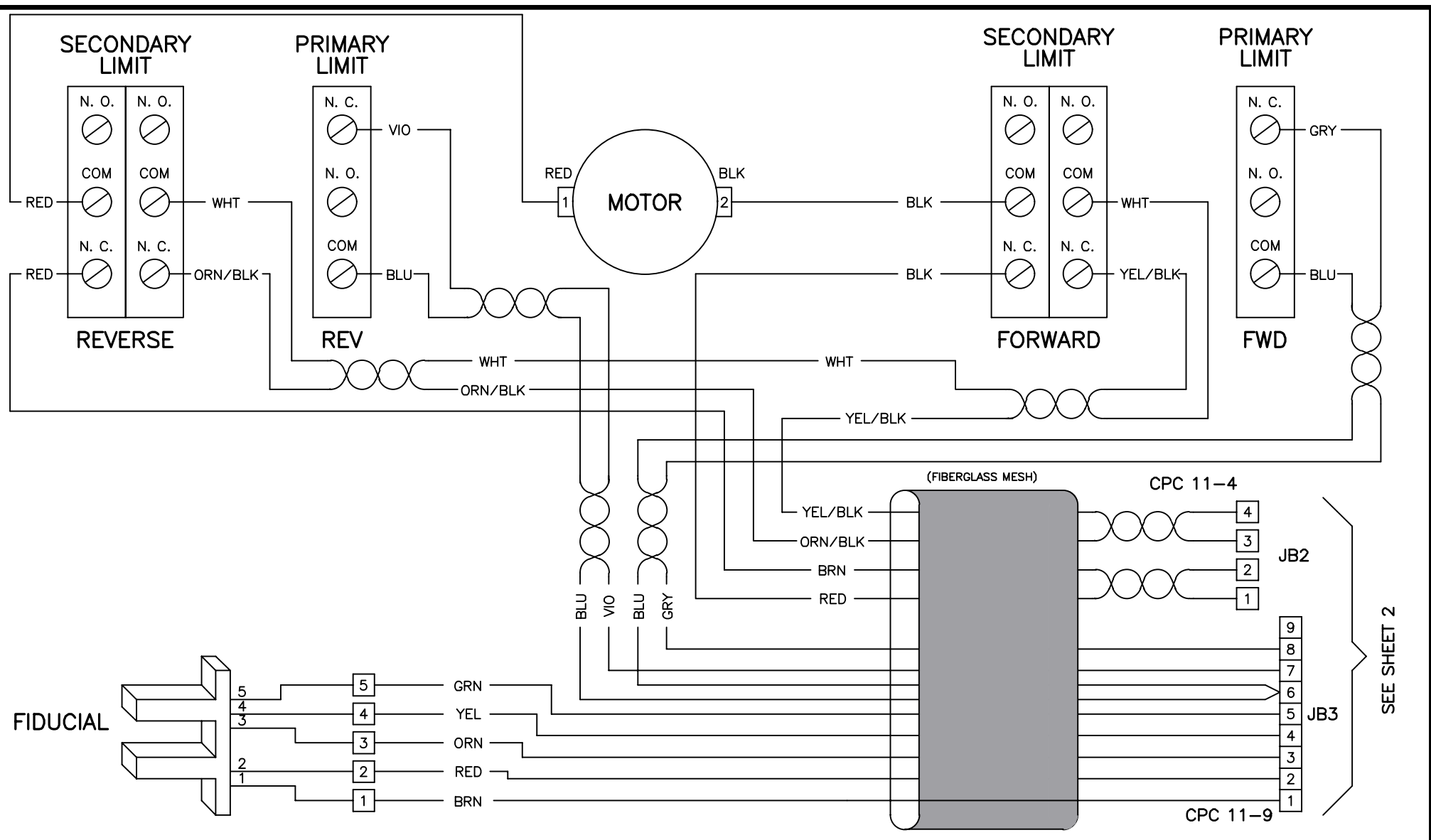

UNIVERSITY OF CALIFORNIA LICK OBSERVATORY		TV FOCUS STAGE WIRING DEIMOS SPECTROGRAPH	
		DES'N BY: B. Alcott	ORIGIN DATE: 05-05-95
REVISION		DRAWN BY:	MODIFY DATE: 09-09-01
09-09-01 ADDED THIS SHEET		PATH: DEIMOS\TVFOCUS	REV. A
		DWG. NO.	NUM. 2 OF 2
		EL-3051	