

# BLOCK DIAGRAM OF SLITMASK STAGE SIGNAL FLOW

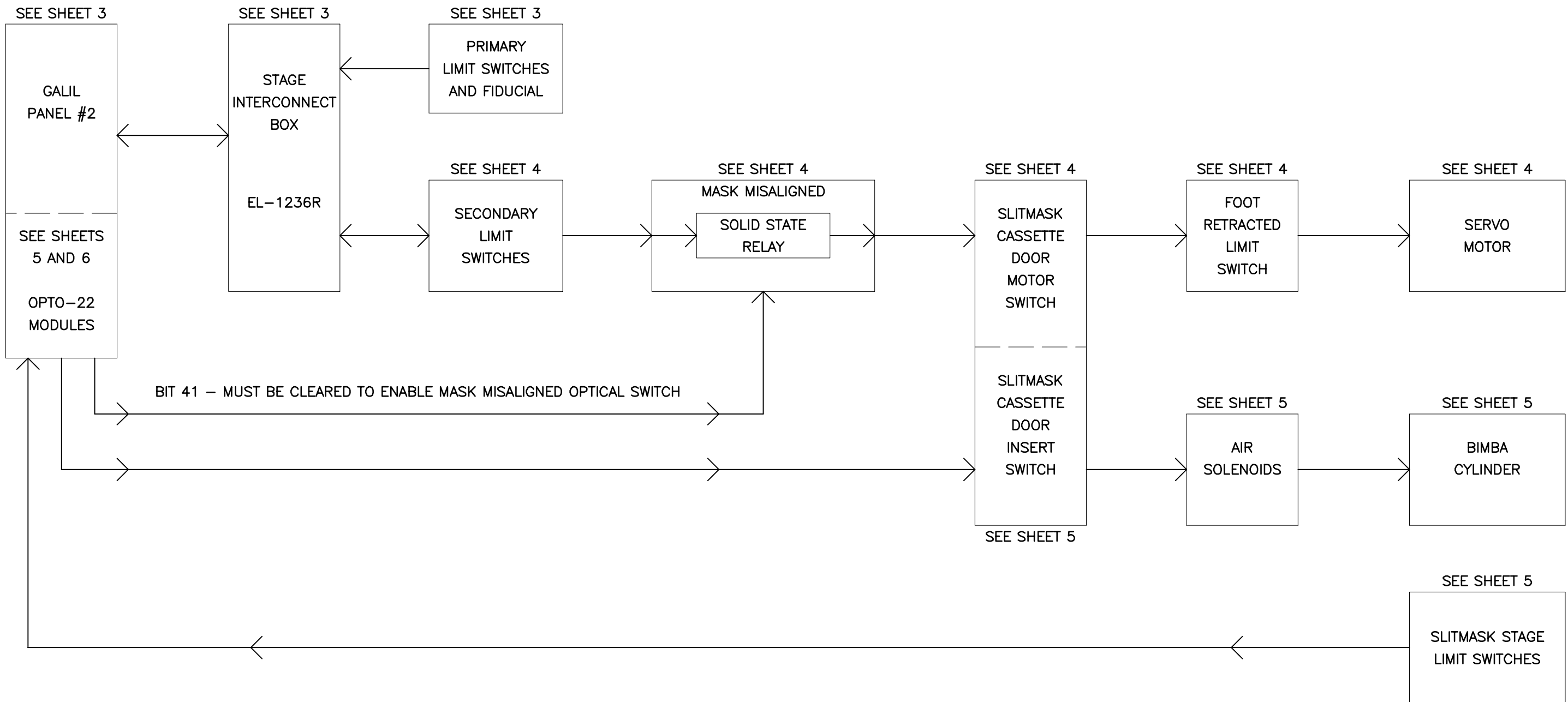

REVISION
04-10-01 ADDED THIS SHEET
07-09-01 ADDED WIRE COLORS AND INCREASED FONT SIZE TO SHEET 9
07-10-01 CHANGED CONNECTOR DESIGNATIONS FROM JE TO JSLIT AND REARRANGED SHEETS
07-13-01 ADDED SLOTTED SWITCH WIRING TO SHEET 4 FROM JSLIT5
09-17-01 CORRECTED MASK_IN_PLACE_2 SIGNAL NAMES ON SHEETS 4, 6, AND 7
06-18-02 CORRECTED LABEL FROM JE6 TO JSLIT3 IN LOWER LEFTHAND OF DRAWING (SHEET 4)

UNIVERSITY OF CALIFORNIA LICK OBSERVATORY		SLITMASK CASSETTE STAGE WIRING DEIMOS SPECTROGRAPH	
DES'N BY: B. Alcott	ORIGIN DATE: 04-28-95	DWG. NO.	NUM. 1 OF 9
Last SN	MODIFY DATE: 06-18-02	EL-3067	
PATH: DEIMOS\SLITMASK			

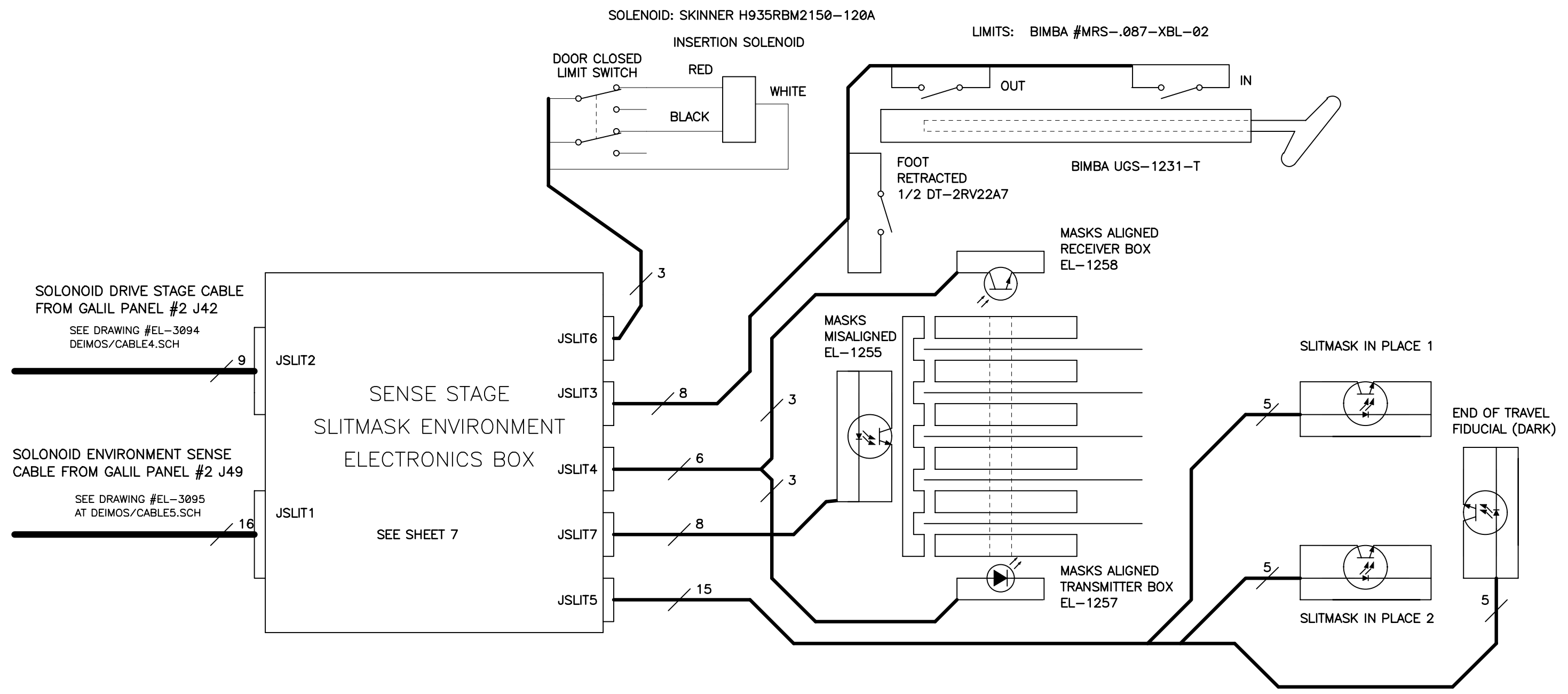

**\*\* OPTICAL INTERRUPTERS MUST BE ENABLED TO CORRECTLY READ STATE OF SWITCH. ISSUE THE COMMAND: CB41**

REVISION	
11-11-97	CHANGED STAGE DESIGNATION TO 'E'
07-18-98	ADDED ALL DRAWINGS CONNECTED TO ENVIRONMENT SENSING AND COMBINED ALL DRAWINGS LB
10-12-99	ADDED SECOND 'MASK INSERTED' FIDUCIAL & REMOVED 5K RESISTORS FROM INSERTION SOLENOID TC
01-03-01	ADDED CASSETTE DOOR LIMIT SWITCH
01-19-01	ADDED END OF TRAVEL LIMIT
03-12-01	CHANGED 'MASK INSERTED' LABELS TO 'SLITMASK IN PLACE'
03-12-01	CHANGED ENVIRONMENTAL BOX CONNECTOR LABELS FROM JB TO JE
07-10-01	CHANGED CONNECTOR DESIGNATIONS FROM JE TO JSLIT AND REARRANGED SHEETS

UNIVERSITY OF CALIFORNIA LICK OBSERVATORY		SLITMASK CASSETTE ENVIRONMENT SENSE SYSTEM DEIMOS SPECTROGRAPH	
DES'N BY: B. Alcott	ORIGIN DATE: 04-28-95	DWG. NO.	NUM. 2 OF 9
Last SN	MODIFY DATE: 07-10-01	EL-3067	
PATH: DEIMOS\SLITMASK	REV.B		

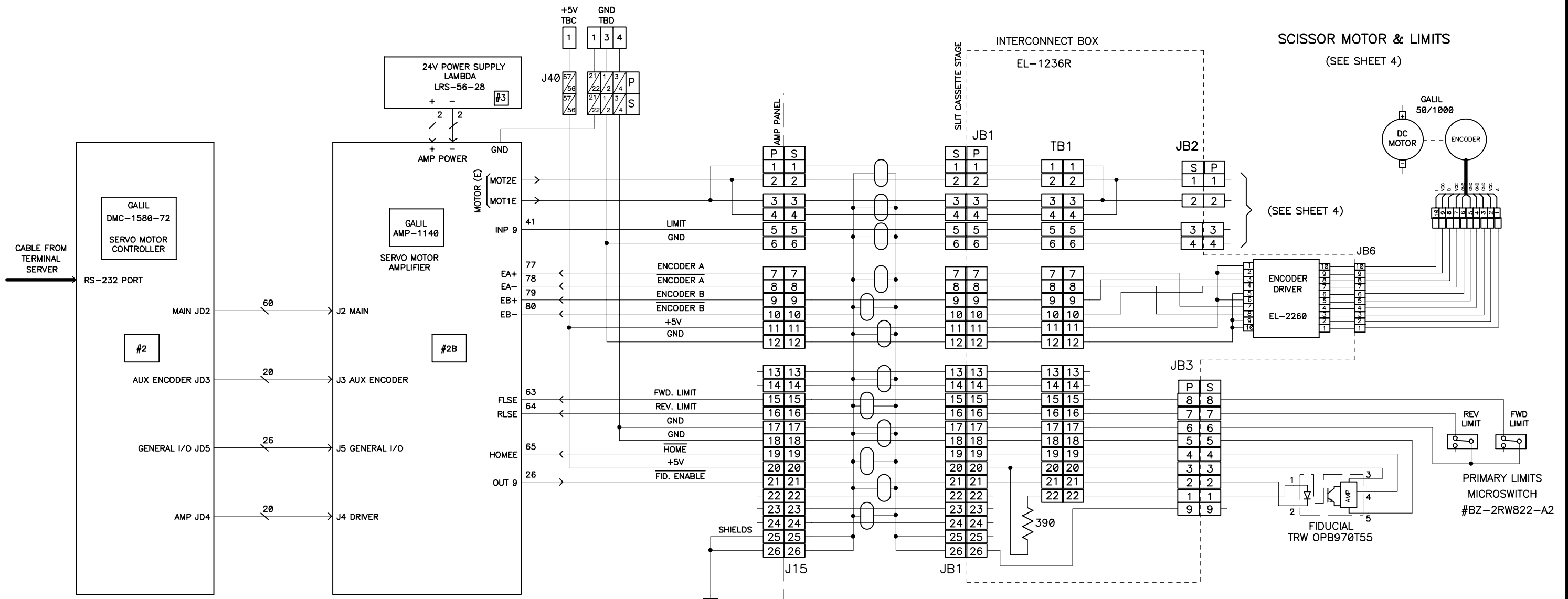

NOTE: ON EACH AMP-1140, INCOM & LSCOM ARE JUMPERED TO +5V.

NOTE: WIRE SHIELDS TO CHASSIS GROUND POINT.

AMP 205840-3  
205839-3  
BELDEN 9768 CABLE

See EL-3091 -1D  
DEIMOS/CABLE1

REVISION

08-09-99	CHANGED PRIMARY LIMITS FROM NORMALLY OPEN TO NORMALLY CLOSED SO THAT A BROKEN WIRE IS SENSED AS BEING IN A LIMIT
06-25-00	ADDED JB6 AND SHIELD CONNECTION IN LINE WITH PLUS LEAD OF MOTOR TO SLIT FOOT RETRACTED
11-27-00	CHANGED NAME OF LIMIT SWITCH IN LINE WITH PLUS LEAD OF MOTOR TO SLIT FOOT RETRACTED
12-07-00	CHANGED LOGIC ON SECONDARY LIMITS SIGNAL BACK TO CONTROLLER. NOW THE SIGNAL IS LIMIT INSTEAD OF LIMIT
01-03-01	CORRECTER MOTOR/MOTOR ENCODER WIRING FOR EL-1236R REVERSE-PHASE INTERCONNECT BOX
01-19-01	ADDED ENT OF TRAVEL LIMIT TO SHEET 5
03-12-01	CORRECTED VARIOUS SIGNAL LABELS, ADDED SOLID-STATE RELAY AND DOOR LIMIT SWITCHES AND ADDED NEW 2ND SHEET
07-10-01	CHANGED CONNECTOR DESIGNATIONS FROM JE TO JSLIT AND REARRANGED SHEETS

UNIVERSITY OF CALIFORNIA LICK OBSERVATORY		SLITMASK CASSETTE STAGE WIRING DEIMOS SPECTROGRAPH	
DES'N BY: B. Alcott	ORIGIN DATE: 04-28-95	DWG. NO.	NUM. 3 OF 9
Last SN	MODIFY DATE: 07-10-01	EL-3067	
PATH: DEIMOS\SLITMASK			

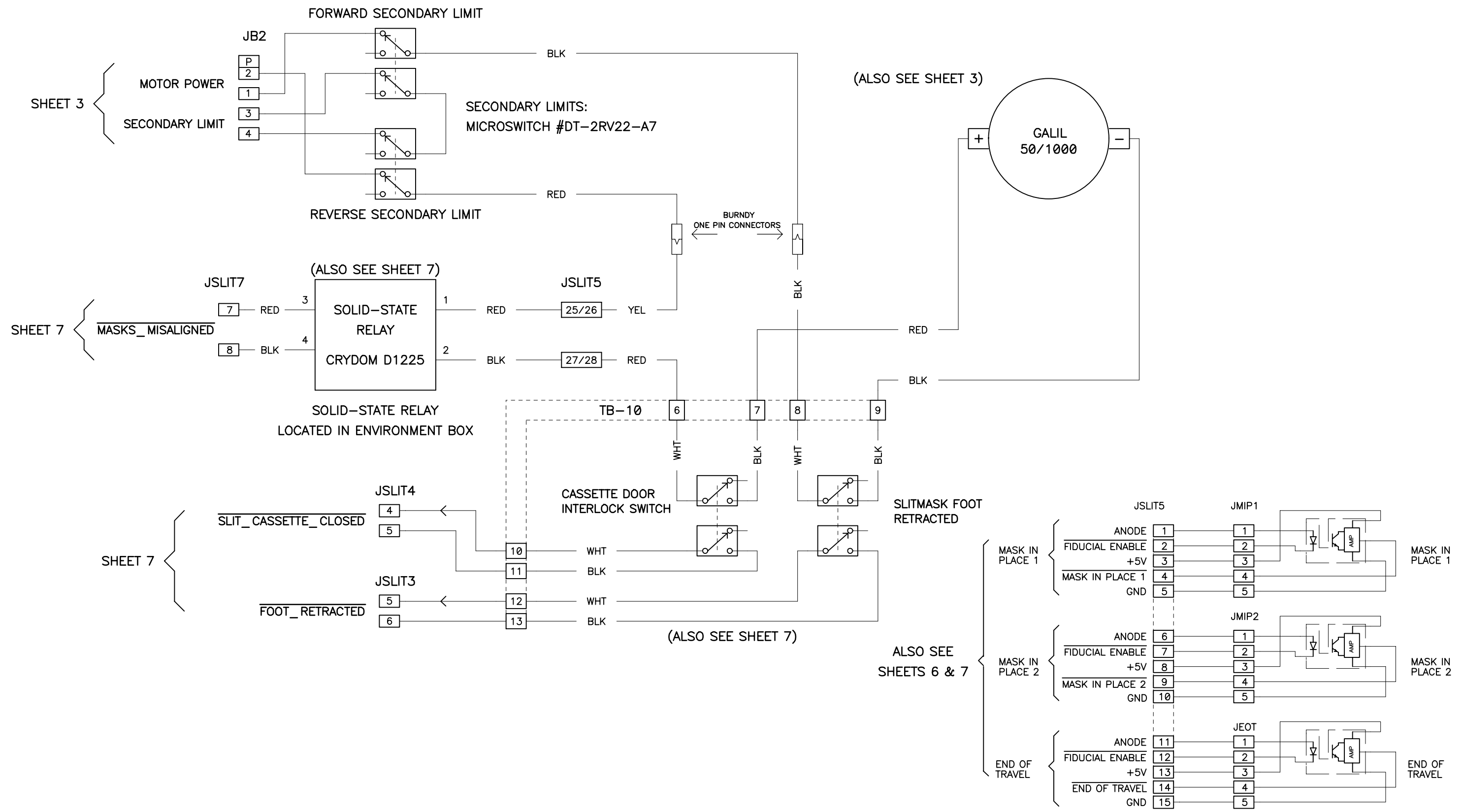

SHEET 3  
MOTOR POWER  
SECONDARY LIMIT

SHEET 7  
MASKS\_MISALIGNED

SHEET 7  
SLIT\_CASSETTE\_CLOSED  
FOOT\_RETRACTED

(ALSO SEE SHEET 3)

ALSO SEE SHEETS 6 & 7

REVISION	
03-12-01	ADDED THIS SHEET
04-10-01	ADDED SOLID-STATE RELAY WIRING
07-10-01	CHANGED CONNECTOR DESIGNATIONS FROM JE TO JSLIT AND REARRANGED SHEETS
07-13-01	ADDED WIRING FOR SLOTTED SWITCHES FROM JSLIT5
09-17-01	CORRECTED MASK_IN_PLACE_2 SIGNAL NAMES
06-18-02	CORRECTED LABEL FROM JE6 TO JSLIT3 IN LOWER LEFTHAND OF DRAWING

UNIVERSITY OF CALIFORNIA LICK OBSERVATORY		SLITMASK CASSETTE STAGE WIRING DEIMOS SPECTROGRAPH	
DES'N BY: B. Alcott	ORIGIN DATE: 04-28-95	DWG. NO.	NUM. 4 OF 9
Last SN	MODIFY DATE: 06-18-02	EL-3067	
PATH: DEIMOS\SLITMASK			

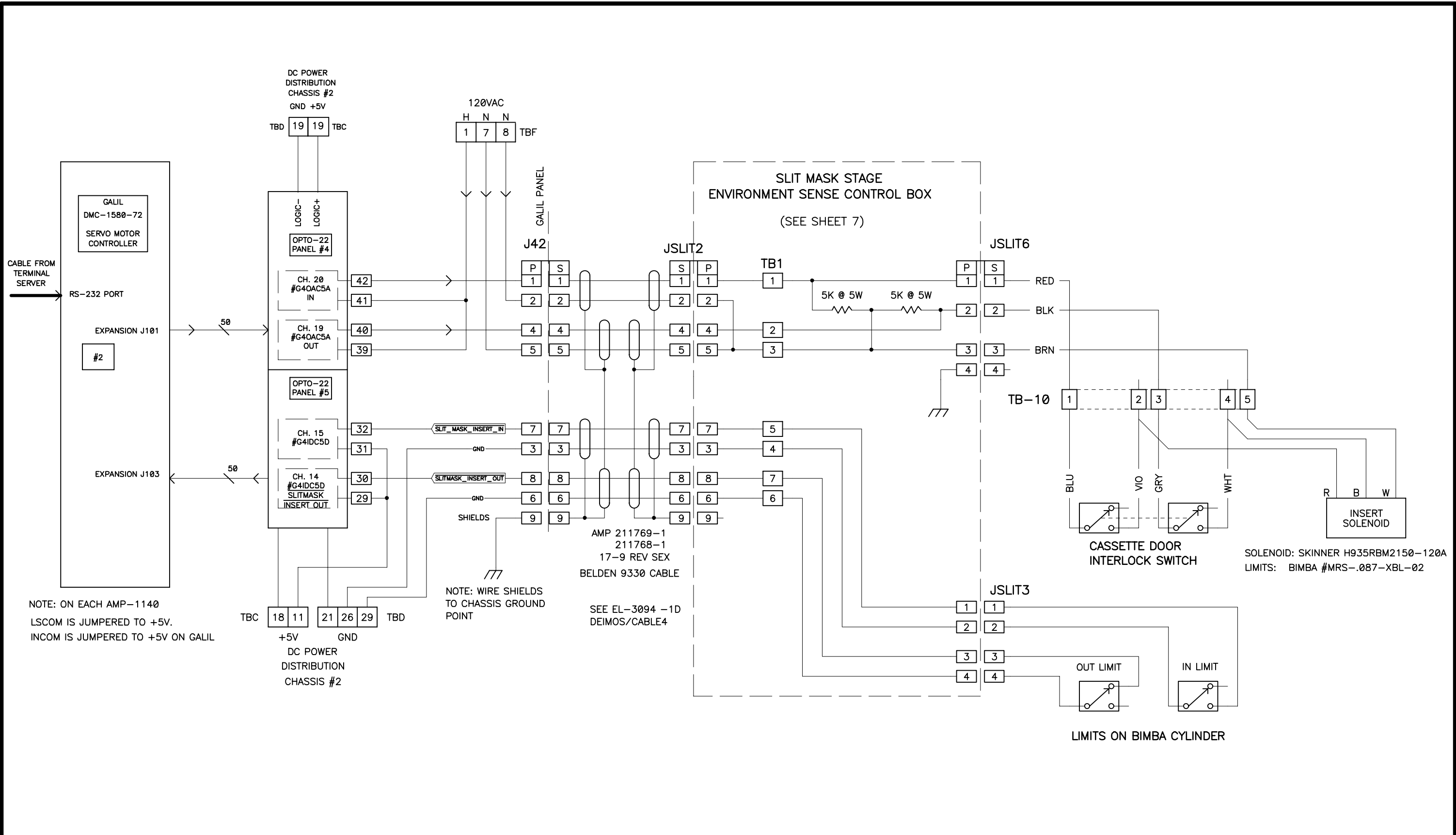

NOTE: ON EACH AMP-1140  
LSCOM IS JUMPERED TO +5V.  
INCOM IS JUMPERED TO +5V ON GALIL

NOTE: WIRE SHIELDS  
TO CHASSIS GROUND  
POINT

AMP 211769-1  
211768-1  
17-9 REV SEX  
BELDEN 9330 CABLE  
SEE EL-3094 -1D  
DEIMOS/CABLE4

SOLENOID: SKINNER H935RBM2150-120A  
LIMITS: BIMBA #MRS-.087-XBL-02

UNIVERSITY OF CALIFORNIA LICK OBSERVATORY		SLITMASK CASSETTE SOLENOID WIRING AND CONTROL DEIMOS SPECTROGRAPH	
DES'N BY: B. Alcott	ORIGIN DATE: 04-28-95	DWG. NO.	NUM. 5 OF 9
Last SN	MODIFY DATE: 07-10-01	EL-3067	
PATH: DEIMOS\SLITMASK			

REVISION	
06-20-97	ADDED SECOND SHEET FOR EXTRA LIMITS & SHIELD WIRING
10-30-97	ADDED STAGE INTERCONNECT BOX
11-11-97	CHANGED STAGE DESIGNATION TO 'E'
07-18-98	ADDED ALL DRAWINGS CONNECTED TO ENVIRONMENT SENSING AND COMBINED ALL DRAWINGS LB
01-03-01	ADDED CASSETTE DOOR INTERLOCK SWITCH AND RENAMED FROM IS_IN_BEAM AND OUT_OF_BEAM TO SLITMASK INSERT IN AND OUT SIGNALS
03-12-01	CORRECTED 'SLITMASK_INSERT_OUT' SIGNAL NAME
03-12-01	CHANGED ENVIRONMENTAL BOX CONNECTOR LABELS FROM JB TO JE
07-10-01	CHANGED CONNECTOR DESIGNATIONS FROM JE TO JSLIT AND REARRANGED SHEETS

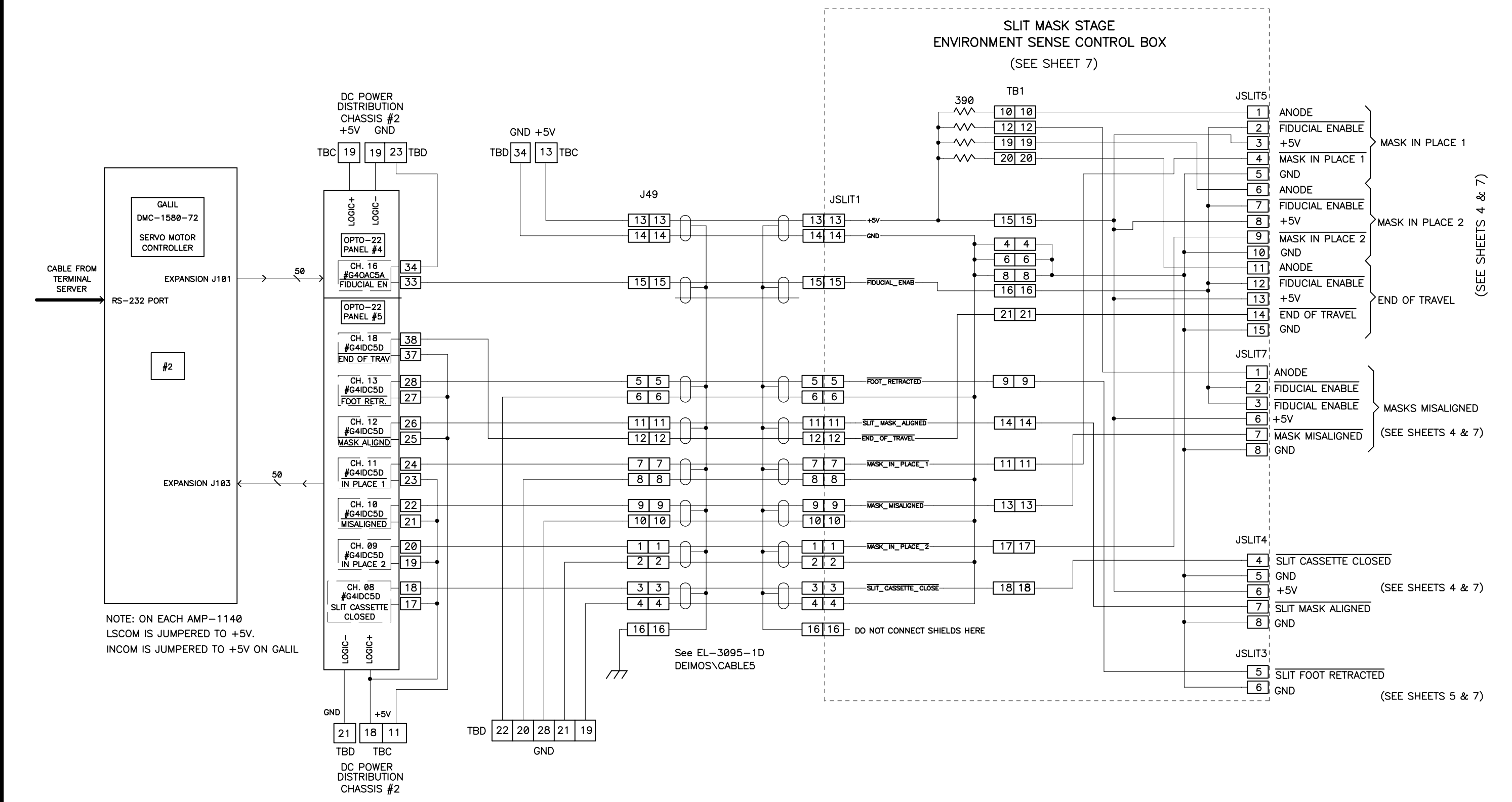

NOTE: ON EACH AMP-1140  
LSCOM IS JUMPERED TO +5V.  
INCOM IS JUMPERED TO +5V ON GALIL.

UNIVERSITY OF CALIFORNIA LICK OBSERVATORY		SLITMASK CASSETTE ENVIRONMENT SENSE CONTROL DEIMOS SPECTROGRAPH	
DES'N BY: B. Alcott	ORIGIN DATE: 04-28-95	DWG. NO.	NUM. 6 OF 9
Last SN	MODIFY DATE: 09-17-01	EL-3067	REV.B
PATH: DEIMOS\SLITMASK			

REVISION	DESCRIPTION
09-07-00	CORRECTED +5V PIN NUMBER ON TB1 FROM 13 TO 15, ADDED PIN 3 TO JB8 AND JB10, REMOVED PIN 2 FROM JB7, INVERTED SIGNAL NAME FOR FIDUCIAL_ENABLE
11-27-00	RENAMED SIGNALS FOR CLARITY
01-03-01	ADDED SLIT CASSETTE CLOSED SIGNAL TO CHANNEL 8 AND END OF TRAVEL SIGNAL TO CHANNEL 18
01-21-01	REWired CONNECTOR JB8 TO ELIMINATE TWO WIRES ON ONE PIN IN MATING CONNECTOR
03-12-01	CORRECTED SEVERAL SIGNAL LABELS
03-12-01	CHANGED ENVIRONMENTAL BOX CONNECTOR LABELS FROM JB TO JE
07-10-01	CHANGED CONNECTOR DESIGNATIONS FROM JE TO JSLIT AND REARRANGED SHEETS
09-17-01	CORRECTED MASK_IN_PLACE_2 SIGNAL NAMES

AMP CPC 211769-1  
FROM SOLENOID  
DRIVER CABLE AT  
GALIL CONTROLLER  
PANEL.  
(SEE SHEET 5)

AMP CPC 206036-1  
FROM SLITMASK  
ENVIRONMENT  
SENSE CONNECTOR  
AT GALIL CONTROLLER  
PANEL.  
(SEE SHEET 6)

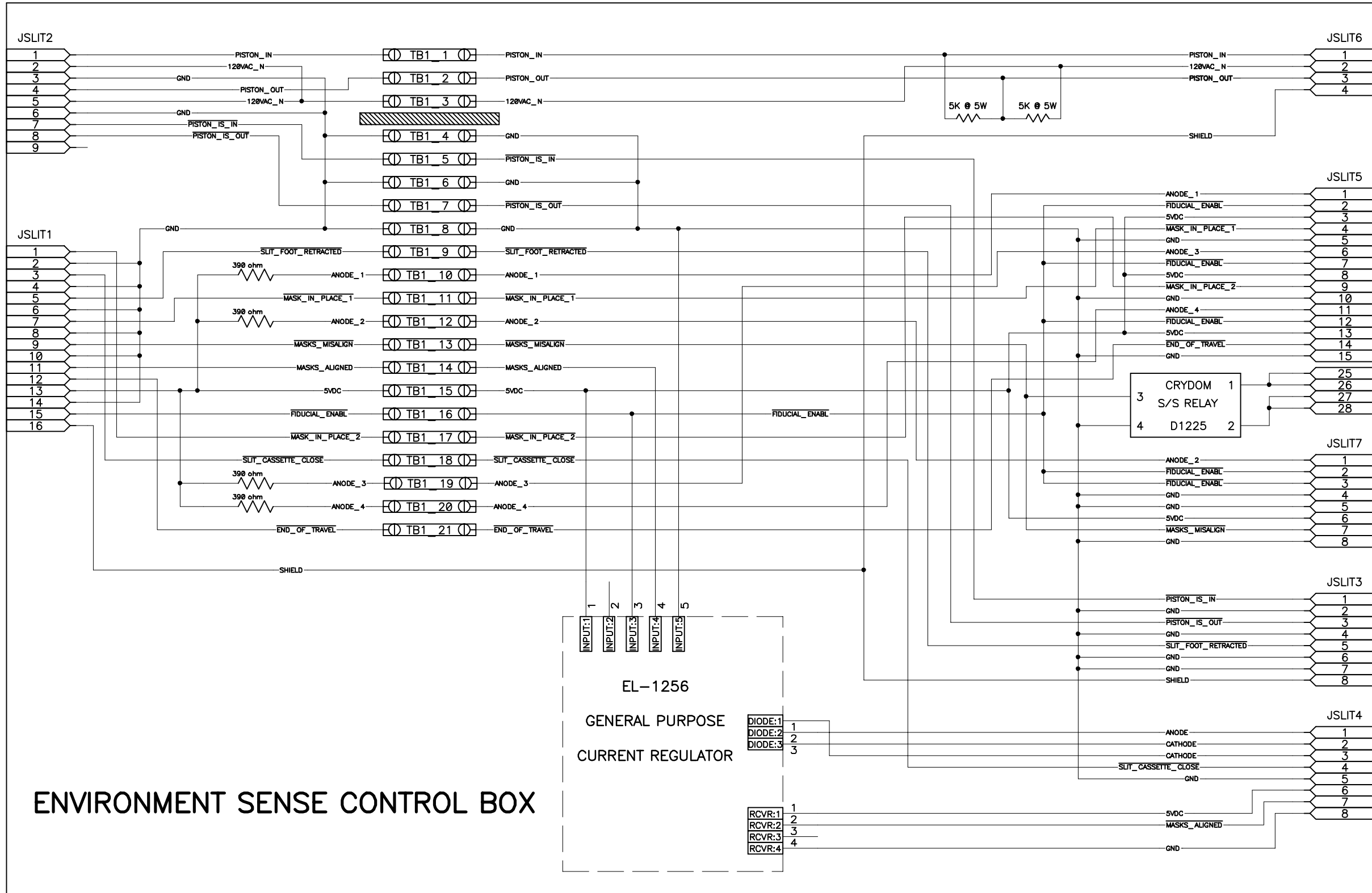

AMP CPC 206425-1  
TO MASK SELECT  
AIR SOLENOID.  
(SEE SHEET 5)

AMP CPC 205840-3  
TO MASK INSERTED  
SENSE FIDUCIAL.  
(SEE SHEETS 4 & 6)

TO SECONDARY LIMITS  
(SEE SHEET 4)

AMP CPC 206433-1  
TO MASKS MISALIGNED  
SENSE FIDUCIAL.  
(SEE SHEETS 4 & 6)

AMP CPC 205841-1  
TO BIMBA PISTON  
LIMIT SWITCHES.  
(SEE SHEETS 5 & 6)

AMP CPC 206433-1  
TO MASK SENSOR  
TRANSMITTER AND  
RECEIVER BOXES.  
(SEE SHEET 4, 6, 9)

## ENVIRONMENT SENSE CONTROL BOX

REVISION	DESCRIPTION
10-12-99	ADDED SECOND 'MASK INSERTED' FIDUCIAL TC
01-03-01	ADDED SLIT_CASSETTE_CLOSED LINE AND CHANGED FOOT_IN TO SLIT_FOOT_RETRACTED AND ADDED END_OF_TRAVEL LIMIT WIRING
01-17-01	REMOVED SHIELD CONNECTION FROM J6 AND J9 TO CASE AND CONNECTED THEM TO J4 16
01-21-01	REWired CONNECTOR JB8 TO ELIMINATE TWO WIRES ON ONE PIN IN MATING CONNECTOR
03-12-01	ADDED SOLID-STATE RELAY TO 'MASK MISALIGNED' SIGNAL
03-12-01	CHANGED ENVIRONMENTAL BOX CONNECTOR LABELS FROM JB TO JE
07-10-01	CHANGED CONNECTOR DESIGNATIONS FROM JE TO JSLIT AND REARRANGED SHEETS
09-17-01	CORRECTED MASK_IN_PLACE_2 SIGNAL NAMES

<b>UNIVERSITY OF CALIFORNIA LICK OBSERVATORY</b>		<b>SLITMASK CASSETTE ENVIRONMENT SENSE CONTROL BOX DEIMOS SPECTROGRAPH</b>	
DES'N BY: <b>B. Alcott</b>	ORIGIN DATE: <b>04-28-95</b>	DWG. NO.	NUM. <b>7</b> OF <b>9</b>
Last SN	MODIFY DATE: <b>09-17-01</b>	<b>EL-3067</b>	
PATH: <b>DEIMOS\SLITMASK</b>	REV.B		

## SLITMASK POSITION SENSOR TRUTH TABLE

MASK POSITION	SENSOR			
	MASKS ALIGNED	MASK IN PLACE 1	MASK IN PLACE 2	END OF TRAVEL
IN CASSETTE	1	1	1	1
EXTENDED 0 TO 7.53"	0	1	1	1
EXTENDED 7.53"	0	0	1	1
EXTENDED 7.77"	0	0	0	1
EXTENDED 7.77" TO 10.20"	0	0	0	1
EXTENDED 10.20" TO 23.53"	1	0	0	1
EXTENDED 23.53"	1	1	0	1
EXTENDED 23.77"	1	0	1	1
EXTENDED 26.52 TO SCIENCE	1	0	0	1
SCIENCE	1	0	0	0

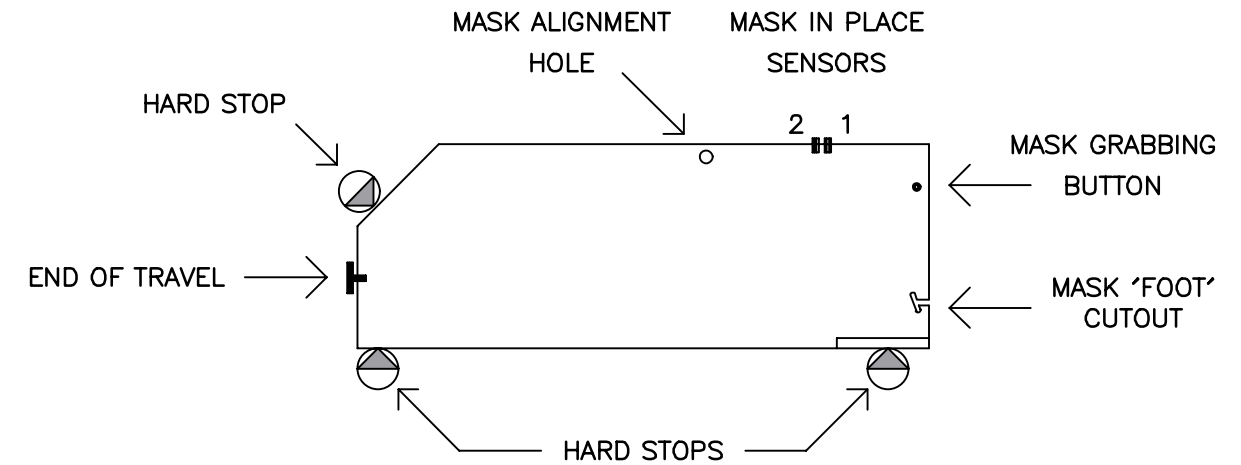

UNIVERSITY OF CALIFORNIA LICK OBSERVATORY		SLITMASK CASSETTE STAGE WIRING DEIMOS SPECTROGRAPH	
DES'N BY: B. Alcott	ORIGIN DATE: 04-28-95	DWG. NO.	NUM. 8 OF 9
Last SN	MODIFY DATE: 01-03-01	<b>EL-3067</b>	
PATH: DEIMOS\SLITMASK	REV.B		

REVISION



CPC 11-8  
206434-1

TO EL-3067 JSLIT4  
(SEE SHEET 6)

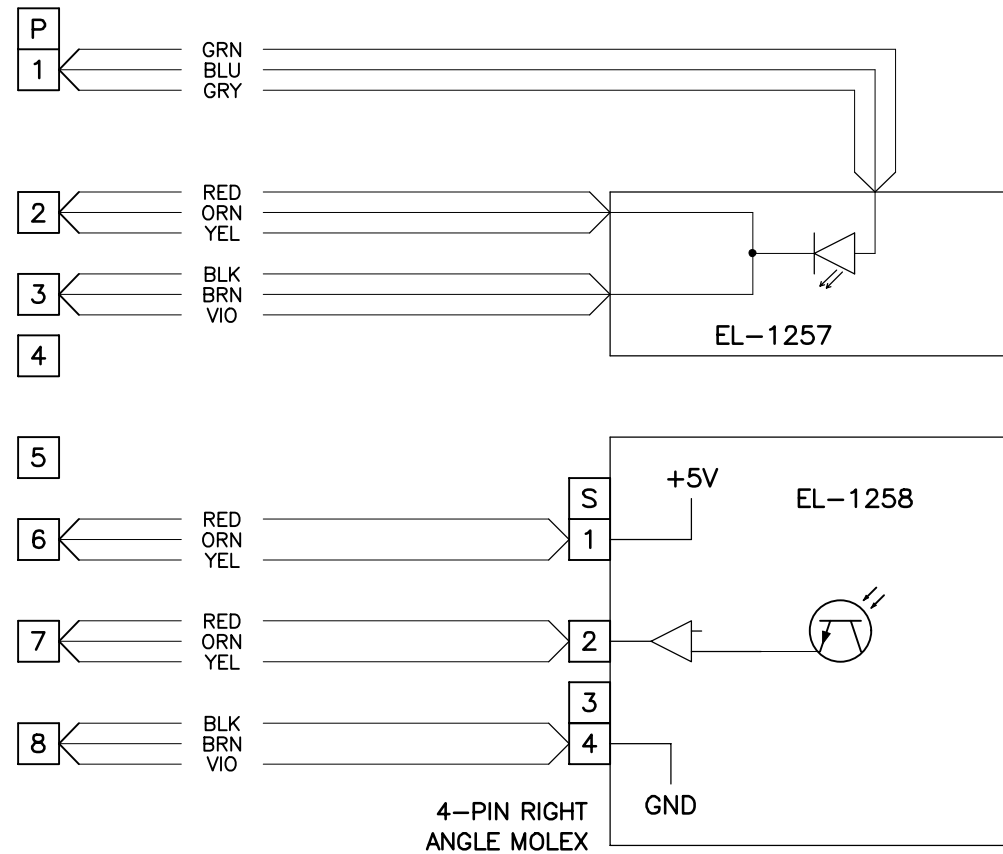

UNIVERSITY OF CALIFORNIA LICK OBSERVATORY		SLITMASK CASSETTE MASK ALIGNMENT SENSOR CABLING DEIMOS SPECTROGRAPH	
DES'N BY: B. Alcott	ORIGIN DATE: 04-28-95	DWG. NO.	NUM. 9 OF 9
Last SN	MODIFY DATE: 07-10-01	EL-3067	
PATH: DEIMOS\SLITMASK	REV.B		

REVISION
03-12-01 CHANGED ENVIRONMENTAL BOX CONNECTOR LABELS FROM JB TO JE
07-09-01 ADDED WIRE COLORS AND INCREASED FONT SIZE
07-10-01 CHANGED CONNECTOR DESIGNATIONS FROM JE TO JSLIT AND REARRANGED SHEETS