

BOTTOM VIEW

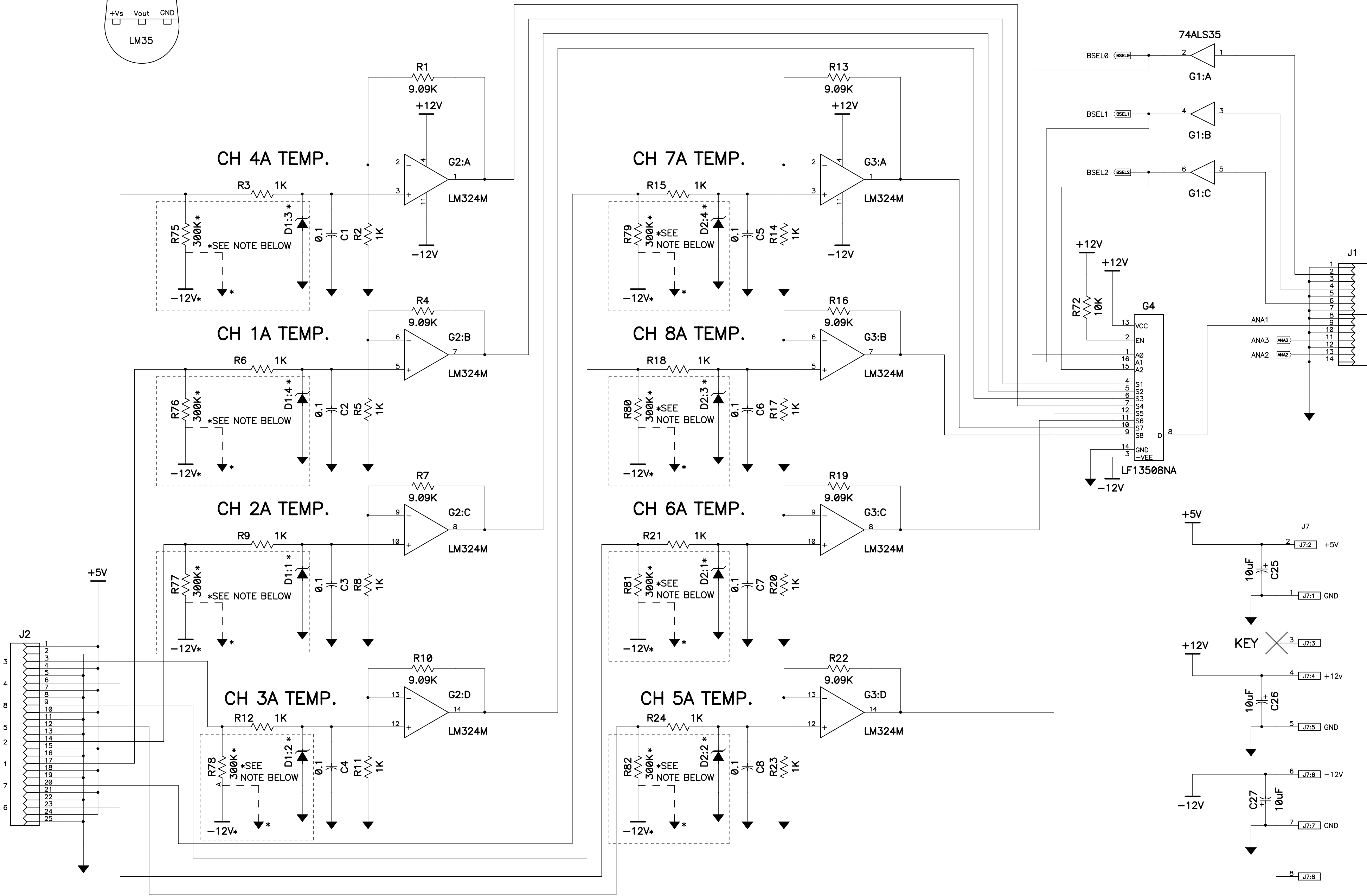
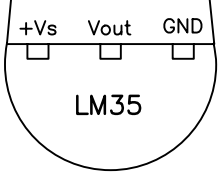

*NOTE: THE PULLDOWN RESISTOR VALUE AND CONNECTION, AND THE USE OF TRANZORBS DEPEND ON THE INTENDED USE. FOR TEMPERATURES, THE RESISTOR IS 300K AND IS CONNECTED TO THE MINUS FIFTEEN VOLT SUPPLY AND THE TRANZORB IS REMOVED. FOR ENCODER INPUTS OR VOLTAGE MONITORING THE RESISTOR IS 1M AND CONNECTED TO GROUND AND THE TRANZORB IS LEFT IN THE CIRCUIT. THIS MUST BE DONE IN GROUPS OF FOUR BECAUSE THE TRANZORB IS PACKAGED FOUR PER IC.

REVISION	
09-30-97	ADDED 1M PULL-DOWN RESISTORS TO INPUTS & CONNECTED J3-25 TO GROUND
12-10-97	CHANGED ANA1 LABEL AND PORT TO ANA2, CHANGED ANA2 LABEL AND PORT TO ANA3
07-26-99	REMOVED TRANZORBS
08-16-99	MADE CHANGES TO ALLOW EITHER BIPOLAR TEMPERATURE OR POSITIVE LEVEL INPUTS
04-12-01	CORRECTED SUPPLY VOLTAGES TO BE +/-12V INSTEAD OF +/-15V

Last Ser # Used: 30

UNIVERSITY OF CALIFORNIA LICK OBSERVATORY		24 ANALOG INPUT BOARD	
DES'N BY: B. Alcott	ORIGIN DATE: 05-23-97	DWG. NO.	NUM. 1 OF 3
DRAWN BY:	MODIFY DATE: 04-12-01	EL-1230-2S	
PATH: MULTIPURPOSE\EL-1230\ANALOG24		REV.A	

BOTTOM VIEW

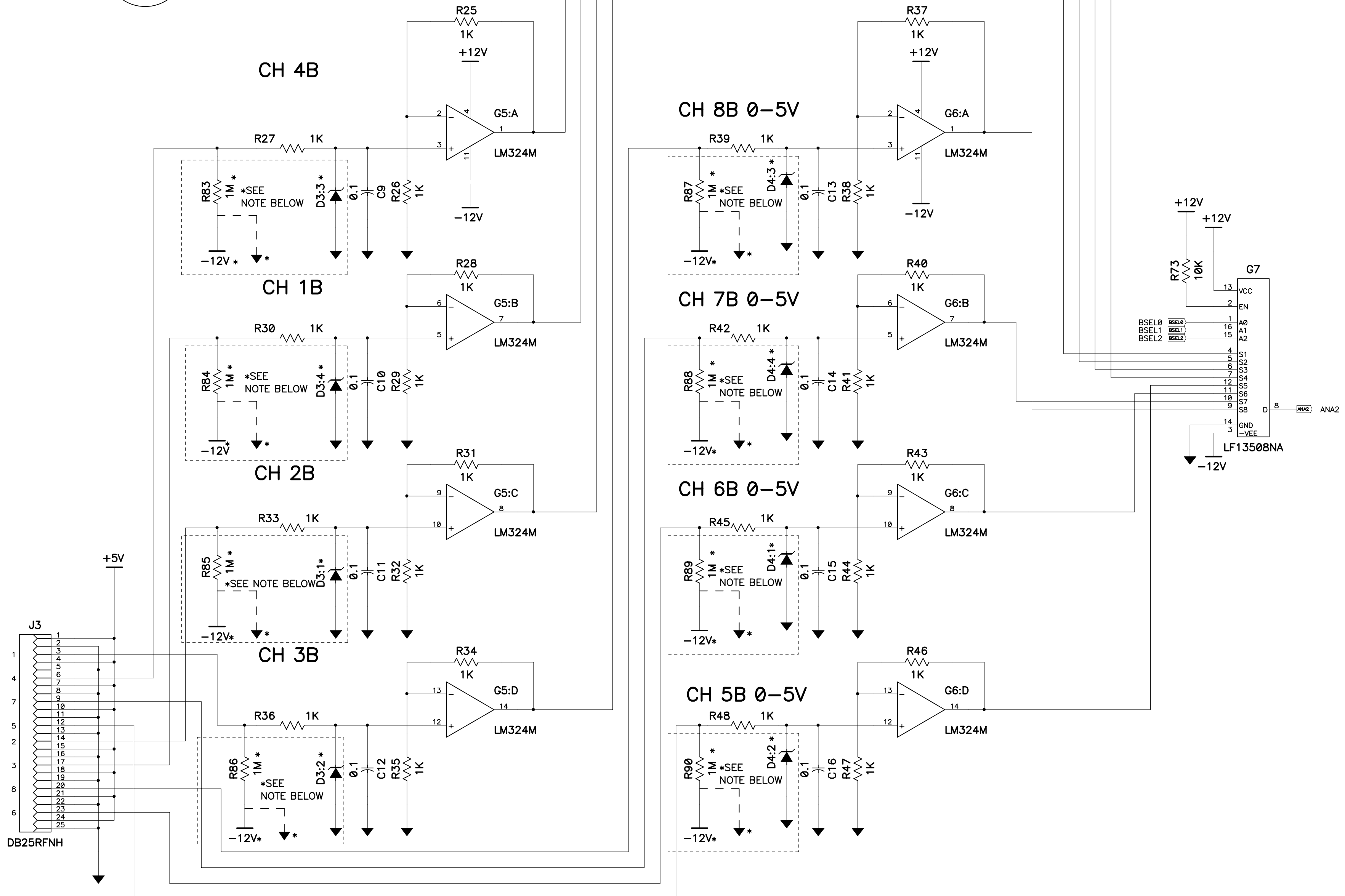
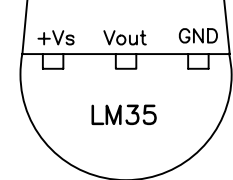

*NOTE: THE PULLDOWN RESISTOR VALUE AND CONNECTION, AND THE USE OF TRANZORBS DEPEND ON THE INTENDED USE. FOR TEMPERATURES, THE RESISTOR IS 300K AND IS CONNECTED TO THE MINUS TWELVE VOLT SUPPLY AND THE TRANZORB IS REMOVED. FOR ENCODER INPUTS OR VOLTAGE MONITORING THE RESISTOR IS 1M AND CONNECTED TO GROUND AND THE TRANZORB IS LEFT IN THE CIRCUIT. THIS MUST BE DONE IN GROUPS OF FOUR BECAUSE THE TRANZORB IS PACKAGED FOUR PER IC.

REVISION		Last Ser # Used: 30
09-30-97	ADDED 1M PULL-DOWN RESISTORS TO INPUTS & CONNECTED J3-25 TO GROUND	
12-10-97	CHANGED ANA1 LABEL AND PORT TO ANA2	
07-26-99	REMOVED TRANZORBS	
08-16-99	MADE CHANGES TO ALLOW EITHER BIPOLAR TEMPERATURE OR POSITIVE LEVEL INPUTS	
10-21-99	CHANGED ALL FEEDBACK RESISTORS TO 1K AND ALL INPUT PULL-DOWNS TO 1M.	
04-12-01	CORRECTED SUPPLY VOLTAGES TO BE +/-12V INSTEAD OF +/-15V	

UNIVERSITY OF CALIFORNIA LICK OBSERVATORY		24 ANALOG INPUT BOARD	
DES'N BY: B. Alcott	ORIGIN DATE: 05-23-97	DWG. NO.	NUM. 2 OF 3
DRAWN BY:	MODIFY DATE: 04-12-01	EL-1230-2S	
PATH: MULTIPURPOSE\EL-1230\ANALOG24			

BOTTOM VIEW

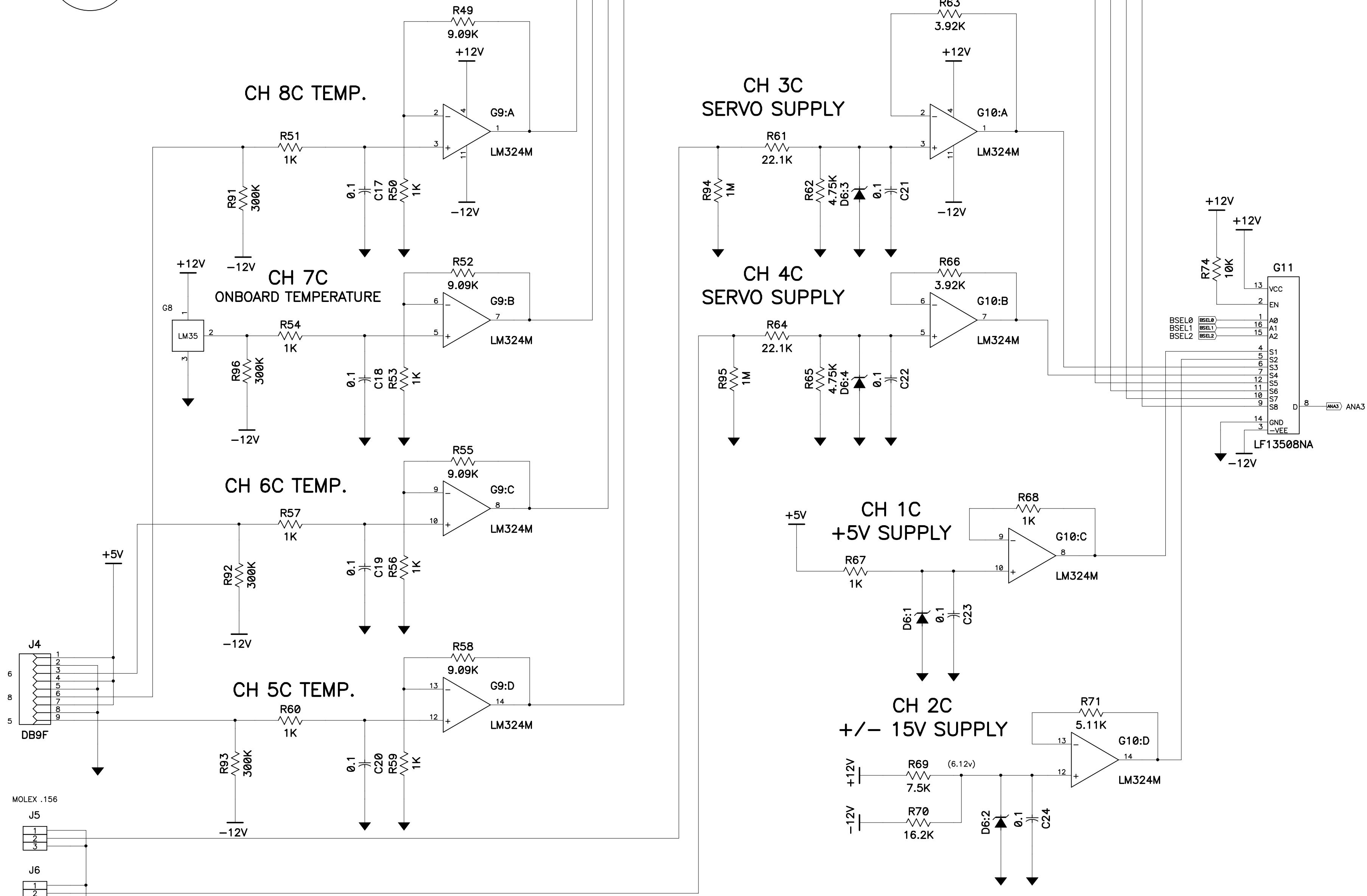
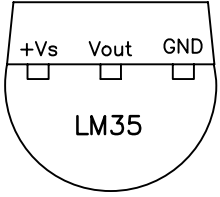

REVISION		Last Ser # Used: 30
09-30-97	ADDED 1M PULL-DOWN RESISTORS TO INPUTS & CONNECTED J3-25 TO GROUND	
12-10-97	CHANGED ANA2 LABEL AND PORT TO ANA3	
07-26-99	REMOVED TRANSORBS	
04-12-01	CORRECTED SUPPLY VOLTAGES TO BE +/-12v INSTEAD OF +/-15v	

UNIVERSITY OF CALIFORNIA LICK OBSERVATORY		24 ANALOG INPUT BOARD	
DES'N BY: B. Alcott	ORIGIN DATE: 05-23-97	DWG. NO.	NUM. 3 OF 3
DRAWN BY:	MODIFY DATE: 04-12-01	EL-1230-2S	
PATH: MULTIPURPOSE\EL-1230\ANALOG24			