

THIS PADDLE IS
NON-STANDARD:
ADDED 5TH LED
FOR LIMIT INDICA-
TIONS

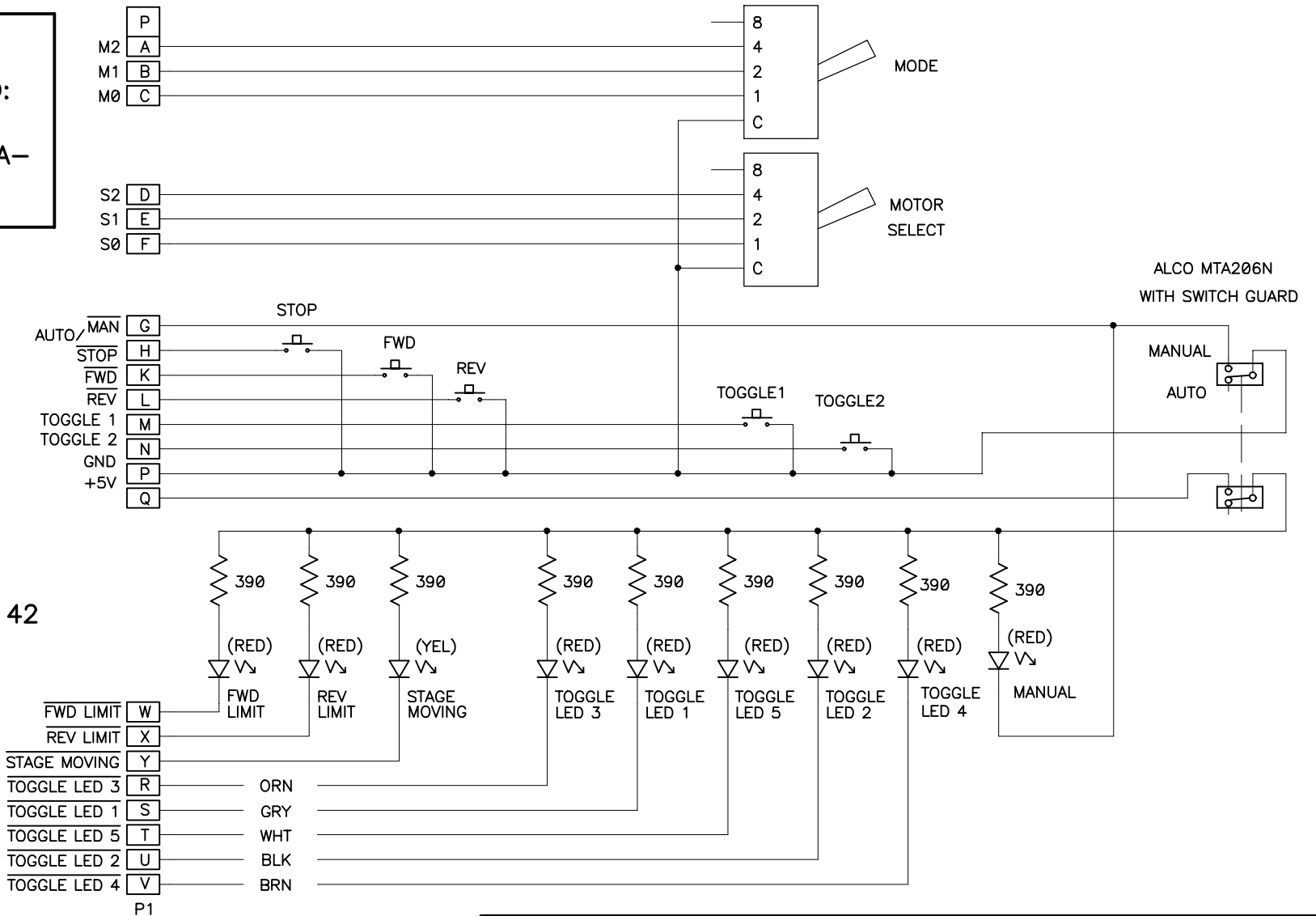

ALSO SEE EL-3142

UNIVERSITY OF CALIFORNIA LICK OBSERVATORY		MANUAL CONTROL PADDLE DEIMOS SPECTROGRAPH	
DES'N BY: B. Alcott		ORIGIN DATE: 05-26-95	DWG. NO. NUM. 1 OF 1
DRAWN BY:		MODIFY DATE: 02-14-02	EL-3141
PATH: DEIMOS\MANCNTRL0		REV. A	

REVISION	
11-30-95	CHANGED SW1 TO DPDT TO TURN OFF LEDS IN AUTO MODE
05-20-96	ADDED STOP BUTTON, STAGE LIMIT AND MOVING LEDS FOR PROGRAMMERS
01-10-00	CHANGED PADDLE CONNECTOR TO 24 PIN MS tc
11-27-01	ADDED TOGGLE LED 5 AND RELABELLED ALL TOGGLE LED'S
02-14-02	ADDED WIRE COLOR FOR STATUS LEDS