

POWER MONITOR CARD

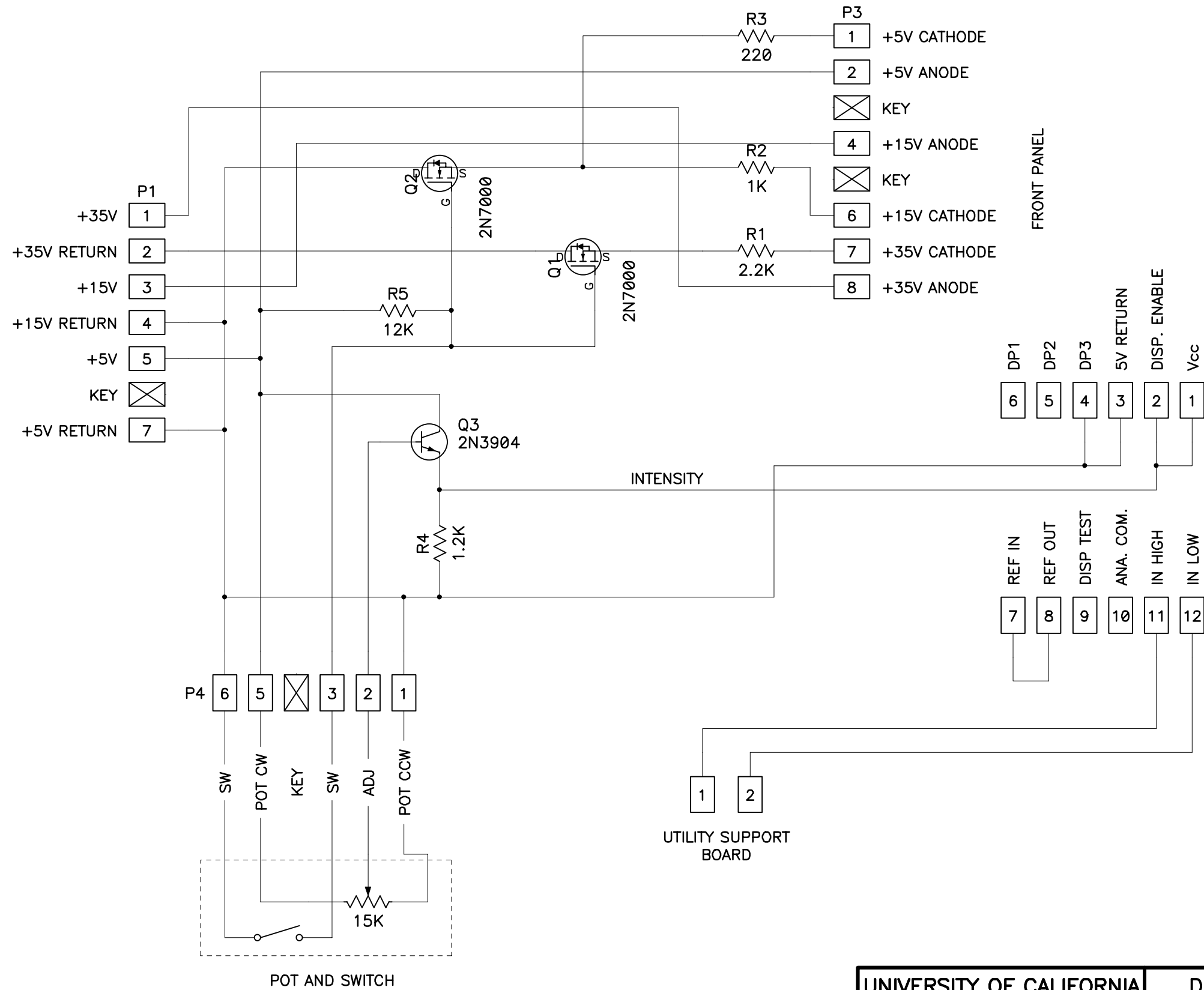

POT AND SWITCH

UTILITY SUPPORT BOARD

FRONT PANEL

PANEL METER

REVISION

2-20-98 REWORK SCHEMATIC FOR SDSU2 CONTROLLER WITH REMOTE POT AND SWITCH
 03-16-01 ADDED EXTERNAL POT/SWITCH

UNIVERSITY OF CALIFORNIA LICK OBSERVATORY		DIMMER CONTROL CIRCUIT SDSU 2 CCD CONTROLLER	
DES'N BY: L. Bresee	ORIGIN DATE: 03-06-95	DWG. NO.	NUM. 1 OF 1
Last SN	MODIFY DATE: 03-16-01	EL-1566-1S	
PATH: SDSU2CCD\BOARDS\EL1566\DIMMER			