



# **Astronomy 80 B: Light**

**Lecture 11: review, photography, vision**

**6 May 2003**

**Jerry Nelson**



# Topics for Today

---

- **Total eclipse of the moon 15 May 2003!!!**
- **Status of field trip**
- **Status of research/term papers**
- **Optical illusion**
- **Pretty picture**
- **Review of mirrors and lenses**
- **Camera principles**

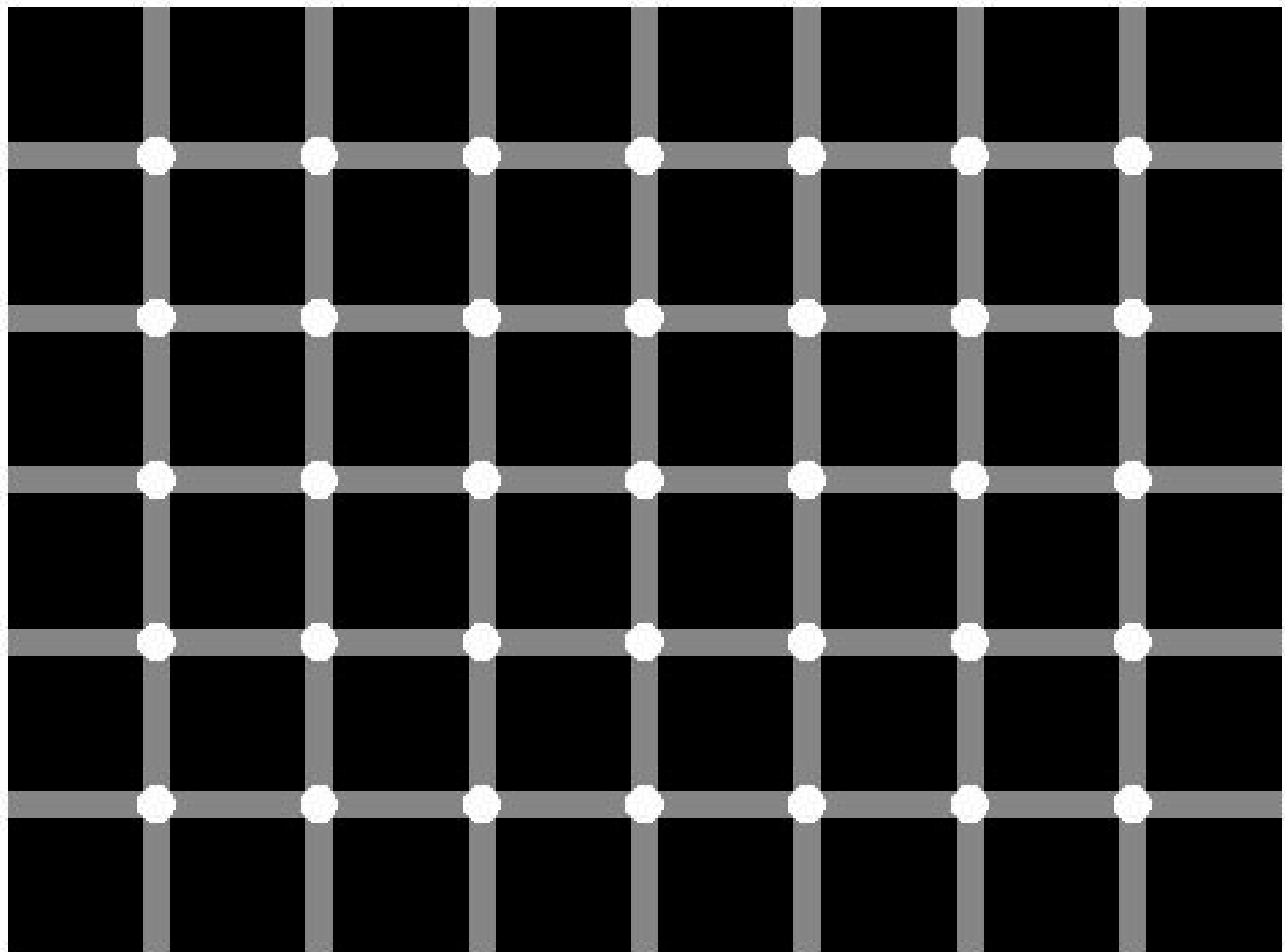



©2001 F. Espenak

[www.MrEclipse.com](http://www.MrEclipse.com)



## Review of mirrors

---

- **Group yourselves into 2-4 people and work together (each make drawings, then talk about what you did)**
- **Recall law of reflection**
  - Draw on a piece of paper:
    - A straight line segment representing a flat mirror
    - A line perpendicular to the mirror
    - a light ray that hits the mirror at the intersection of the mirror and the perpendicular line
    - Indicate the angle of incidence
    - where this ray is reflected
    - Indicate the angle of reflection
  - Do you agree on this drawing? Discuss it until you can agree



## Review of mirrors-2

---

- **Pick up spherical mirror and study it**
- **Apply law of reflection to convex mirror**
  - Draw on a piece of paper:
    - A circular arc representing a convex mirror
    - Label the center (center of curvature)
    - A symmetry line passing through the center
    - Label the focal point
    - An object external to the mirror, near the symmetry line
  - Construct the location of the image of the object, using the three rays we have covered in class
  - Do these rays satisfy the law of reflection?
  - Do you agree on this drawing? Discuss it until you can agree
  - What can you say about the nature of the image?



## Review of mirrors-3

---

- **Continuing**
- **Apply law of reflection to concave mirror**
  - Draw on a piece of paper:
    - A circular arc representing a concave mirror
    - Label the center (center of curvature)
    - A symmetry line passing through the center
    - Label the focal point
    - An object external to the mirror, near the symmetry line but further than the center of curvature from the mirror
  - Construct the location of the image of the object, using the three rays we have covered in class
  - Do these rays satisfy the law of reflection?
  - Do you agree on this drawing? Discuss it until you can agree
  - What can you say about the nature of the image?



## Review of mirrors-4

---

- **Continuing**
- **Apply law of reflection to concave mirror**
  - What happens when the object becomes very close to the mirror surface?
  - What does close mean?
  - Is the law of reflection satisfied?





# Review of lenses

---

- **Apply law of refraction to a transparent interface**
  - Draw on a piece of paper
    - A horizontal line (representing the surface of water)
    - A line perpendicular to the surface
    - A light ray that hits the water at the intersection of the water and the perpendicular line
    - Indicate the angle of incidence
    - Write down Snell's law (how are angles defined?)
    - Where this ray is refracted
    - Indicate the angle of refraction
    - Write the formula for this angle
    - Calculate this angle
  - Do you agree?



## Review of lenses-2

---

- **Apply law of refraction to a prism**
  - Draw on a piece of paper
    - A triangle (representing a prism)
    - A line perpendicular to one surface
    - A light ray that hits the surface at the intersection of the surface and the perpendicular line
    - Indicate the angle of incidence
    - Write down Snell's law
    - Where this ray is refracted
    - Indicate the angle of refraction
    - How the ray exits the prism
    - What would variations in the index of refraction do?
  - Do you agree?



## Review of lenses-3

---

- **Apply law of refraction to a convex lens**
  - Draw on a piece of paper
    - A convex lens
    - A line of symmetry perpendicular to the lens
    - Indicate the focal locations
    - An object on the left of the lens, to the left of the focus
    - Construct the image location
      - Use 3 rays
      - Is image real?
      - Is image erect?
      - Is image magnified?
  - Do you agree?



# Camera

- Key components of a camera

2003 May 6

**FIGURE 4.1**

(a) Photograph of a large-format camera. The brass cylinder contains the lens. The back of this camera can carry either a ground glass screen for viewing or a film holder. (b) The essential parts of this camera.

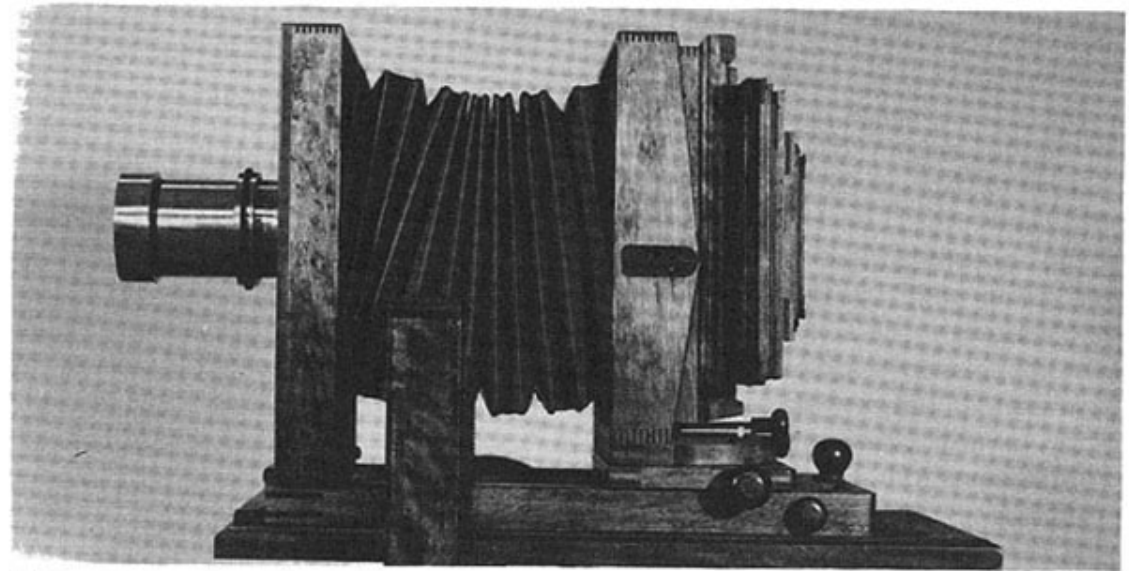

(a)

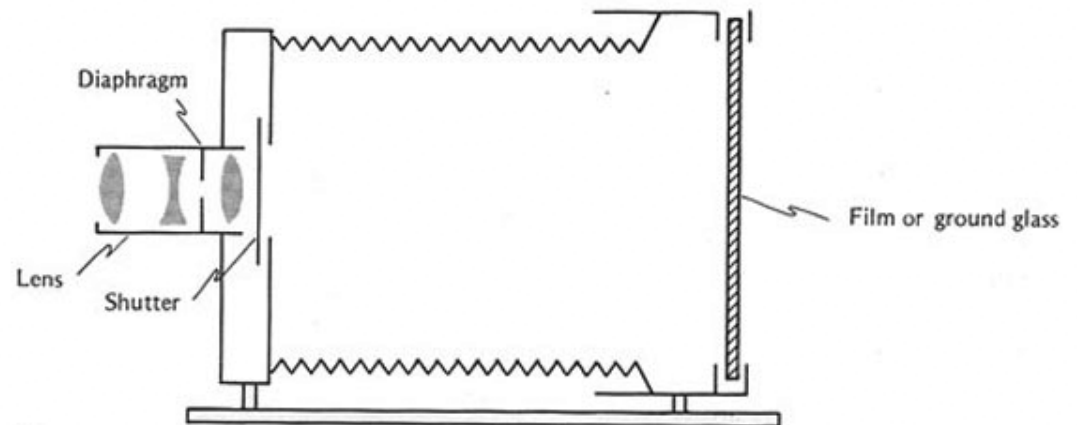

(b)



# What is a camera?

---

- **light tight box:** This keeps out stray light so only the desired light gets to the film
- **lens:** This gathers the incident light and focuses it onto the film
- **viewfinder:** This allows the person to see what they are taking a picture of and compose and focus the image properly
- **focus mechanism:** This allows the focal position of the camera to be adjusted so the image of the desired object ends up on the film plane. As distance to object varies, focus changes.
- **diaphragm:** This adjustable device controls the amount of light that gets into the camera and hence to the film
- **shutter:** This controls the length of the exposure; how much time light is admitted to the film
- **film plane / focal plane:** Where the film must be accurately placed to match the in focus image the camera lens has made
- **Film:** The light sensitive material used to record the image. Commonly film, but more recently other solid state detectors replace film



- Depth of focus

- Depth of field

2003 May 6

**FIGURE 4.2**

(a) Depth of focus. For the range of film positions shown, the image of the fixed object will be acceptably in focus.  
(b) Depth of field. Objects within the range shown are acceptably in focus for the particular lens-film distance chosen.

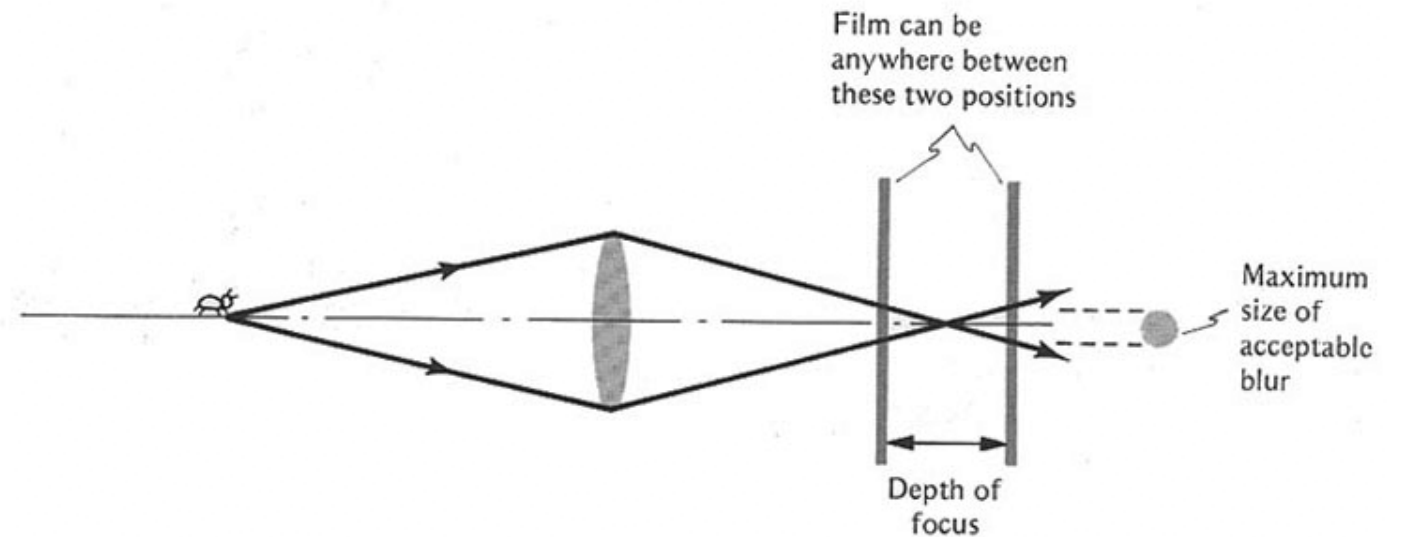

(a)

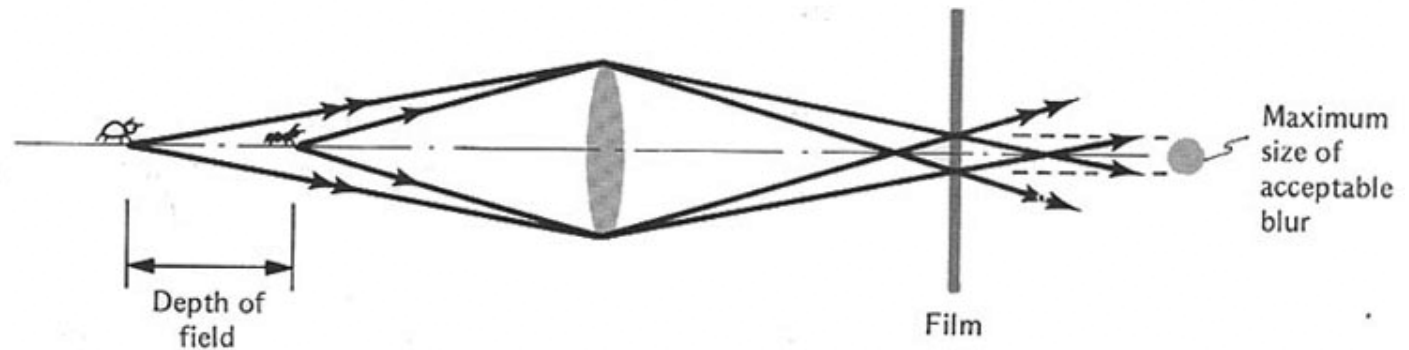

(b)

**FIGURE 4.3**

(a) The traditional view of a traditional photographer looking into the back of the camera, with a black cloth thrown over his head to exclude stray light so he can see the screen. (b) The actual view that the photographer may have as he looks into the back of his view camera.



(a)

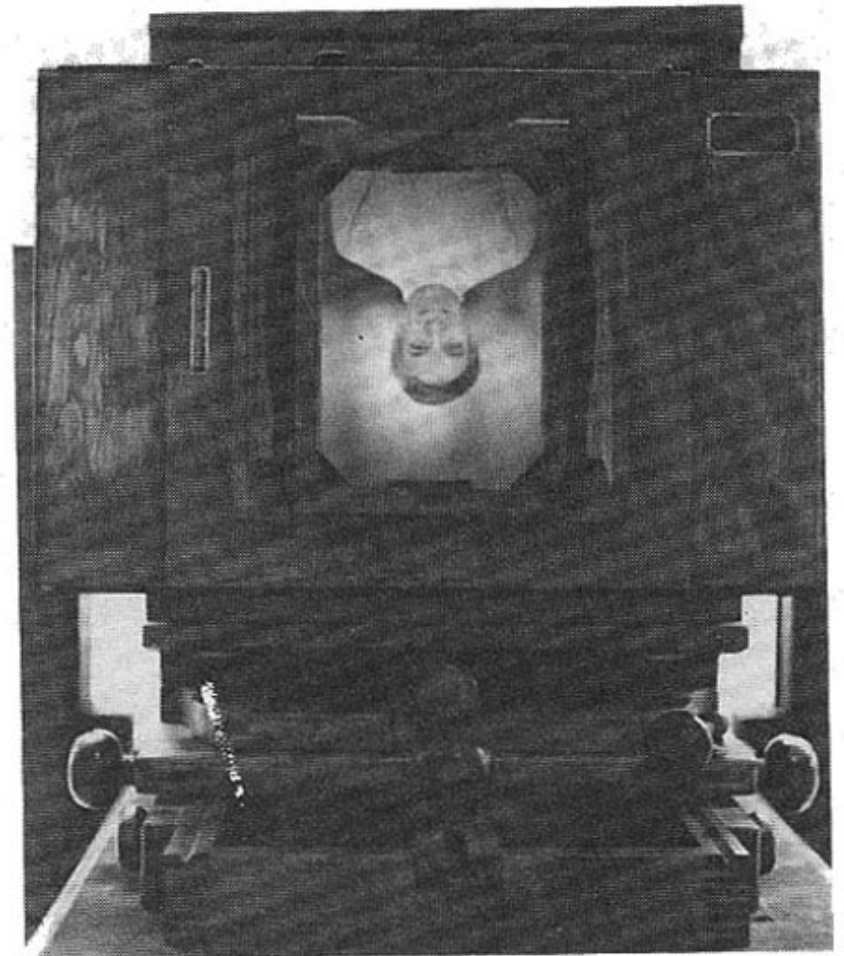

(b)

# Single lens reflex camera

- Key components of an SLR

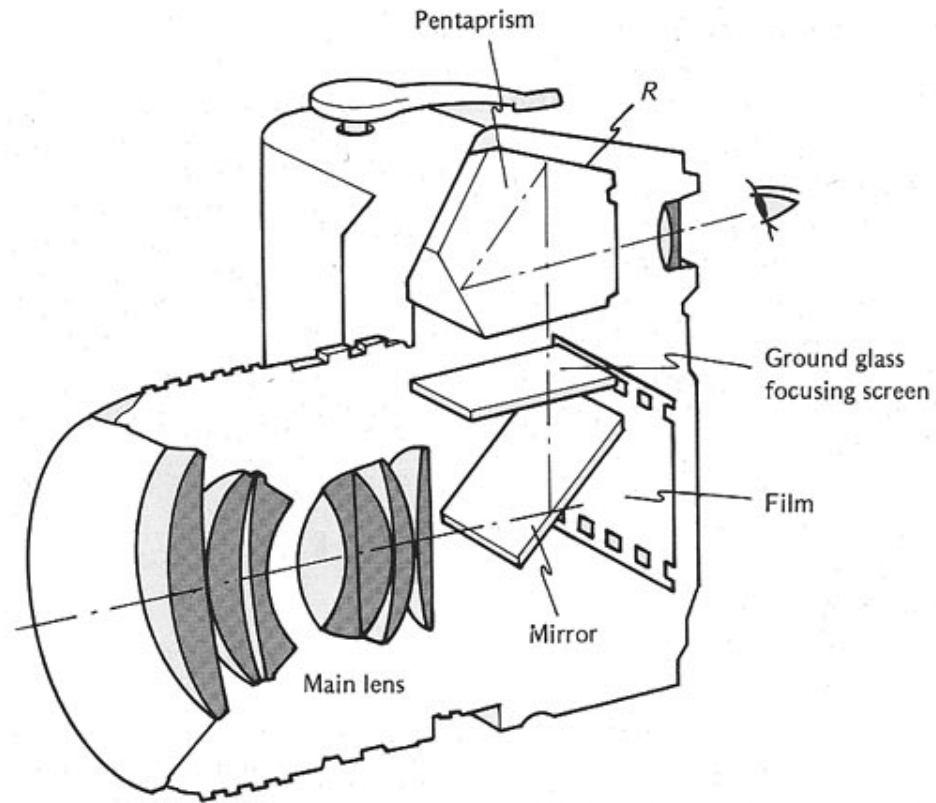

**FIGURE 4.4**

The main parts of a modern single-lens reflex camera. The distance of the light path from the lens to the film is the same as from the lens to the focusing screen by way of the mirror. The pentaprism inverts the image on the focusing screen before the photographer sees it. The roof *R* of the pentaprism consists of two faces that provide extra reflections perpendicular to the plane of the figure in order to reverse the image in that direction as well.



# Focusing onto a screen

- Biprisms will shift an out of focus image, opposite directions for each prism, by an amount proportional to the defocus

FIGURE 4.5

(a) A biprism of the type often mounted in the center of the ground-glass screen of an SLR. (b) Effect of one of the prisms: When image  $I$  is on the focal plane, it is seen undisplaced (left). When it is below (or above) the focal plane, it is seen displaced, as  $I'$  (right). (c) Photograph of the resulting split-image effect, when in focus (left) and out of focus (right). (Note the ring of microprisms around the central biprism.)

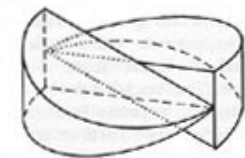

(a)

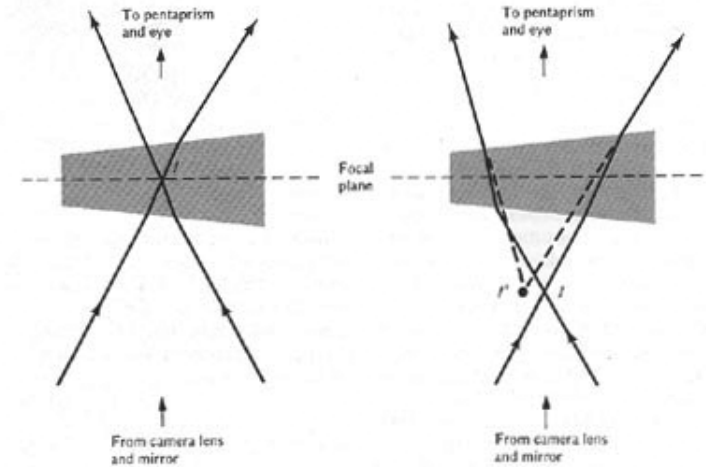

(b)

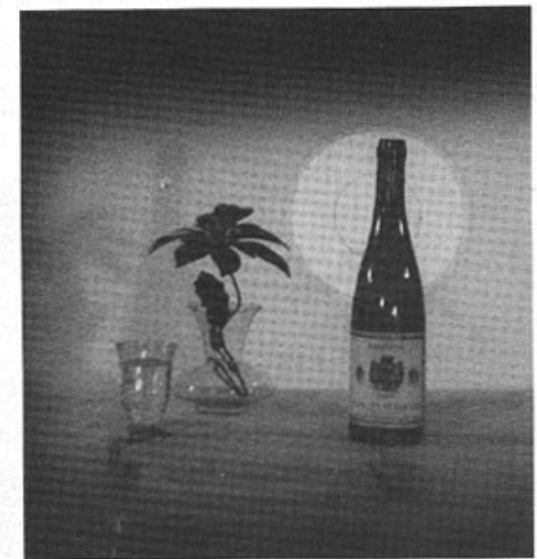

(c)



- **Distance scales on the focussing part of a camera lens**
- **Depth of field is also sometimes shown**



(a)



(b)

**FIGURE 4.6**

Photograph of distance scales on photographic lenses. (a) Distance scales in meters and feet. Pointers not only indicate the distance of best focus, but also bracket the depth of field. Note how the close distances are spread out, and the far distances are crowded together on this scale, corresponding to the way the lens crowds together the images of distant objects. (b) Size of common objects as seen in viewfinder may serve as distance indicator.



- Rangefinder principles

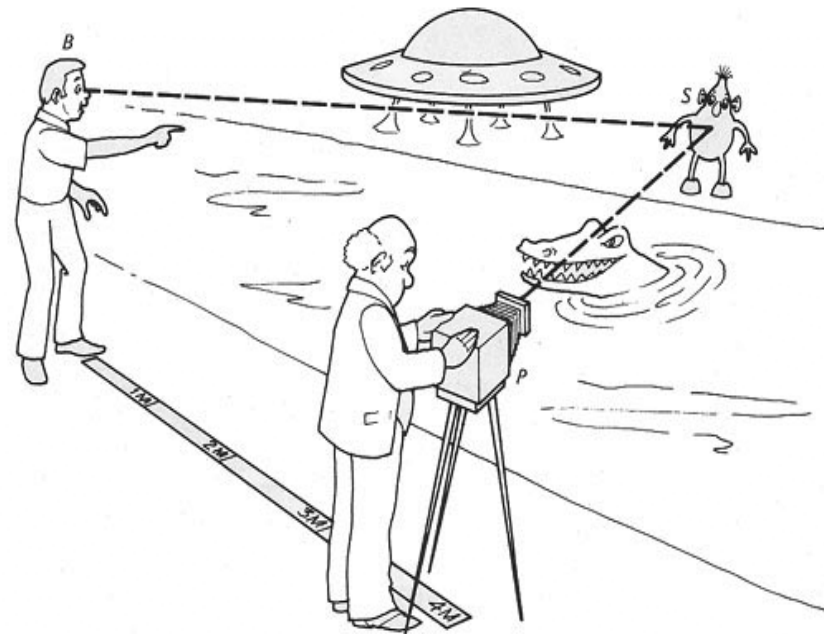

(a)

**FIGURE 4.7**

(a) The rangefinder problem: Our photographer  $P$  wants to measure the distance  $\overline{PS}$  to a subject  $S$ . A bystander  $B$ , a little distance away, is also staring at  $S$ . (b) Solution to the rangefinder problem.

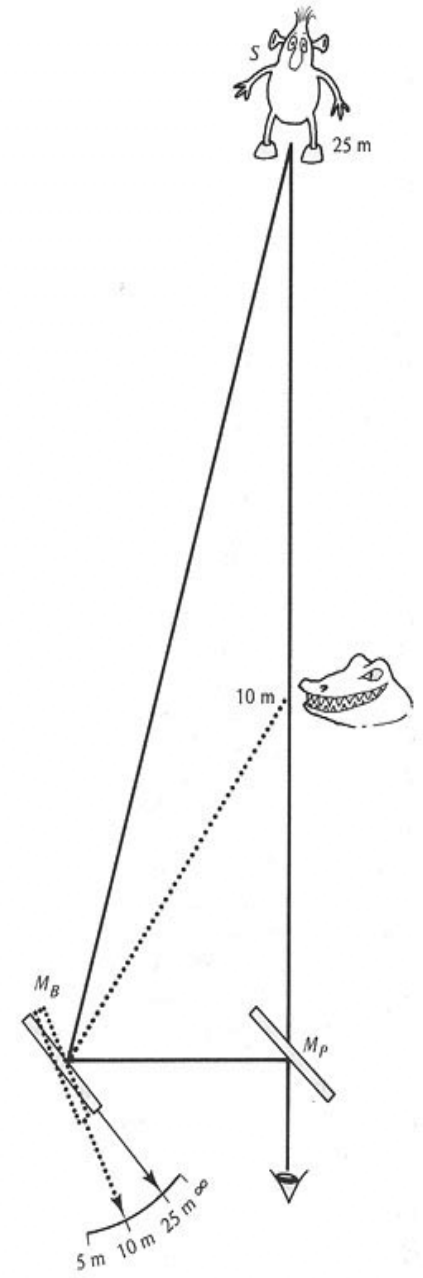

(b)



# Rangefinder focusing

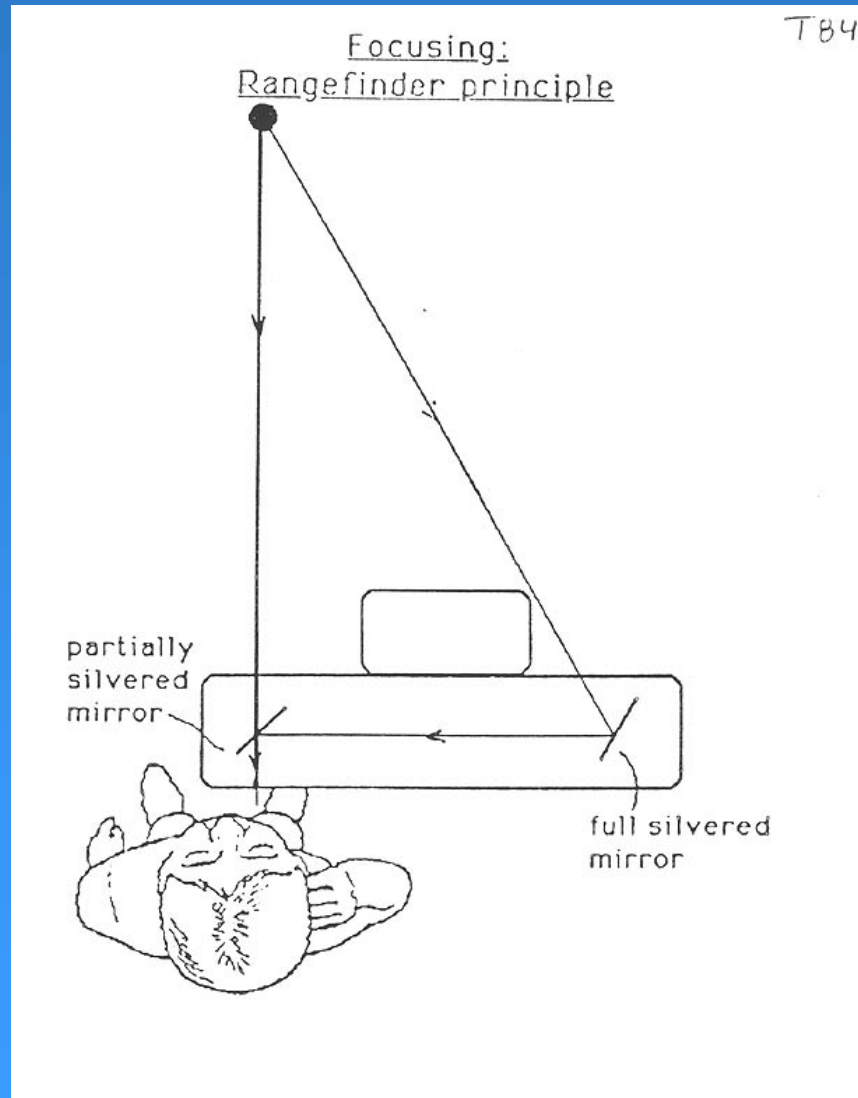



# Effect of camera focal length

Effects of camera focal length on image size

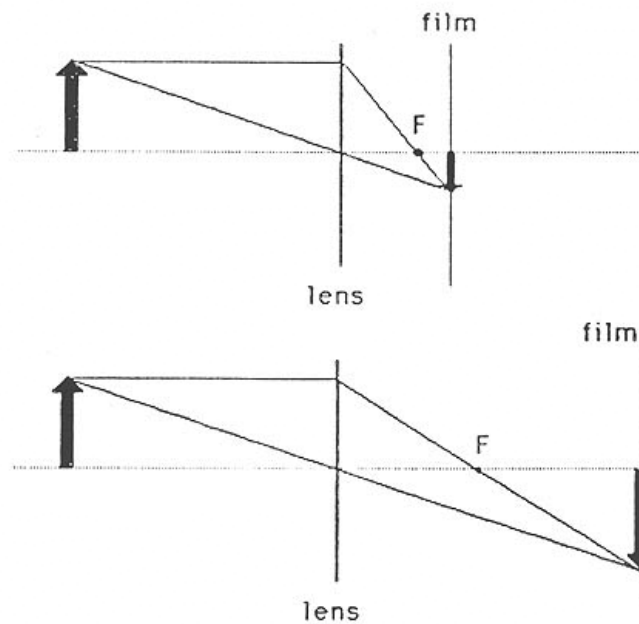

short focal length  
(large angle of view)

long focal length  
(small angle of view)

